

ODU MINI-SNAP[®] SERIES L,K,B

HDMI    
ODU HIGH SPEED DATA TECHNOLOGY



ODU MINI-SNAP® SERIES L,K,B

FEATURES

- Quick and easy mating and demating, also robot-controlled
- Blind mating and demating in difficult-to-reach places
- Low space requirements on the receptacles
- Definite and secure locking conditions
- Easy cleaning of the connector plug housing
- High connector density
- Low power requirement

APPLICATIONS

- Medical
- Industrial
- Test and measurement
- Military and security
- Automotive



All shown connectors are according to IEC 61984:2008 (VDE 0627:2009); connectors without breaking capacity (COC).

ODU MINI-SNAP® is UL-approved under file E110586.

All dimensions are in mm.
Some figures are for illustrative purposes only.
Subject to change without notice. Errors and omissions excepted.
We reserve the right to change our products and their technical specifications at any time in the interest of technical improvement.
This publication supersedes all prior publications.

This publication is also available as a PDF file that can be downloaded from www.odu-connectors.com.

Issue: 2024-05

Data transmission protocols

The contact arrangement of an ODU data transmission connector differs from a standard data transmission connector due to the robust ODU specific design. However, the ODU design meets the electrical specifications of the respective standard data transmission protocol.

TABLE OF CONTENTS

Clickable page numbers

THE ODU CORPORATE GROUP	<u>4</u>
PRODUCT INFORMATION	<u>10</u>
Push-Pull connector series at a glance	<u>12</u>
Specific attributes of series L, K and B	<u>13</u>
Functional principle of the Push-Pull locking	<u>14</u>
Facts & figures	<u>15</u>
CONFIGURATION GUIDELINE	<u>16</u>
Correct configuring – step by step	<u>18</u>
ODU MINI-SNAP® SERIES L	<u>22</u>
Summary ODU MINI-SNAP® series L	<u>24</u>
The LP locking principle	<u>26</u>
Styles	<u>28</u>
Keyings	<u>39</u>
Contact inserts and PCB layouts	<u>40</u>
Cable collet system	<u>64</u>
Accessories	<u>66</u>
ODU MINI-SNAP® SERIES K	<u>74</u>
Summary ODU MINI-SNAP® series K	<u>76</u>
The LP locking principle	<u>78</u>
Styles	<u>80</u>
Keyings	<u>88</u>
Contact inserts and PCB layouts	<u>90</u>
Cable collet system	<u>108</u>
Accessories	<u>110</u>
ODU MINI-SNAP® SERIES B	<u>114</u>
Summary ODU MINI-SNAP® series B	<u>116</u>
The FP locking principle	<u>118</u>
Styles	<u>120</u>
Keyings	<u>125</u>
Contact inserts and PCB layouts	<u>126</u>
Cable collet system	<u>144</u>
Accessories	<u>146</u>
TOOLS, CRIMP INFORMATION, PROCESSING INSTRUCTIONS, ACCESSORIES	<u>154</u>
Crimping tools/assembly tools	<u>156</u>
Spanner wrench	<u>158</u>
Nutdriver for slotted mounting nut	<u>158</u>
Removal tools for crimp-clip-contacts	<u>159</u>
TECHNICAL INFORMATION	<u>160</u>
International protection classes acc. IEC 60529:2013 (VDE 0470-1:2014)	<u>162</u>
Principle of watertightness	<u>163</u>
Housing materials and insulator materials	<u>164</u>
Termination technologies	<u>165</u>
Conversions/AWG	<u>166</u>
Current load of turned contacts	<u>167</u>
Operating voltage	<u>168</u>
Electro magnetic compatibility (EMC)	<u>169</u>
Autoclaving	<u>170</u>
Technical terms	<u>171</u>

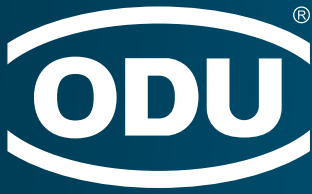

ODU group overview

- 80 years of experience in connector technology
- 2,700 employees worldwide
- Sales subsidiaries in Germany, Austria, China, Denmark, France, Hong Kong, Italy, Japan, Korea, Sweden, UK and the US as well as 5 production and logistics sites
- All technologies under one roof: Design and development, machine tooling and special machine construction, injection, stamping, turning, surface technology, assembly and cable assembly

As of May 2024

Worldwide customer proximity

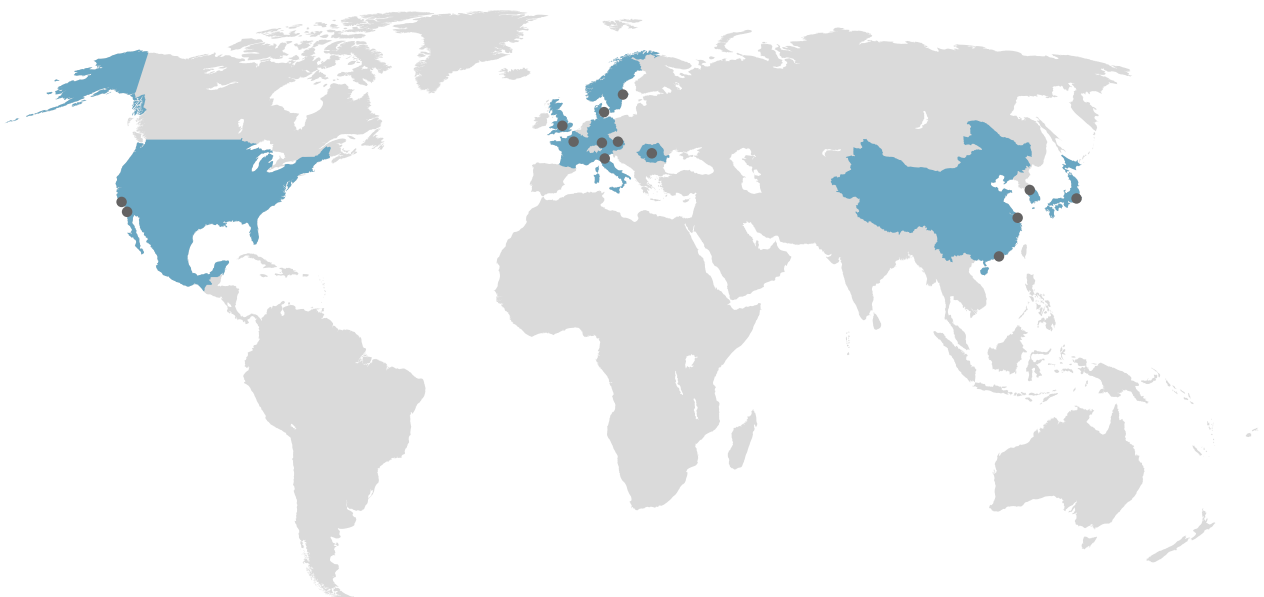



Certificates & approvals

- ISO 9001
- IATF 16949
- ISO 13485
- ISO 14001
- ISO 50001
- Wide range of UL, CSA, VG and VDE approvals
- UL Wiring Harnesses certified

For a complete list of our certifications and approvals, please visit our website.

ODU serves the markets





ODU MINI-SNAP®



[Table of Contents](#)



PRODUCT INFORMATION

Push-Pull connector series at a glance	<u>12</u>
Specific attributes of the series L, K and B	<u>13</u>
Functional principle of the Push-Pull locking	<u>14</u>
Facts & figures	<u>15</u>

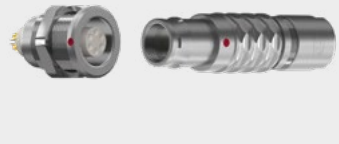
THE COMPLETE SERIES OF ODU PUSH-PULL CONNECTORS AT A GLANCE

	Keying	Size	No. of possible mechanical keyings	Plug diameter in mm	Max. cable diameter in mm	Number of max. contacts	Solder	Crimp	PCB	IP protection degree IEC 60529:2013 in mated condition	IP protection degree IEC 60529:2013 in unmated condition	From page
ODU MINI-SNAP® L 	Pin and groove	00	4	6.4	3.5	04	•	•	•	IP50	Up to IP68	22
		0	8	9	5.6	10						
		1	8	11.5	7.7	16						
		2	8	14.5	9.9	26						
		3	8	17.5	11.9	30						
		4	8	25	16	40						
ODU MINI-SNAP® K 	Pin and groove	0	8	11	5	10	•	•	•	Up to IP68	Up to IP68	74
		1	8	13	7	16						
		2	8	16	9	26						
		3	8	19	10.5	30						
		4	8	25	14	40						
ODU MINI-SNAP® B 	Pin and groove	0	8	9.4	5	10	•	•	•	IP68	Up to IP68	114
		1	9	12	7	16						
		2	10	15	9	26						
		3	13	18	10.5	30						

CIRCULAR CONNECTORS WITH PUSH-PULL LOCKING IN METAL CONNECTOR PLUG HOUSING



ODU MINI-SNAP® is the ideal self-locking circular connector for a wide range of applications. Whether used for transmitting power, signals, data or other media, this circular connector in its robust metal connector plug housing impresses customers with its exceptional quality, high reliability and ideal handling characteristics.

The Push-Pull principle reliably ensures that the connector will not come loose during application in practice: Once plugged in, the ODU MINI-SNAP® locks itself into the receptacle automatically. It cannot be separated by pulling on the cable. Instead, the connector can easily be separated from the receptacle by pulling on the outer housing.

The ODU MINI-SNAP® is available in a wide range of sizes and models. In addition, you can choose between three base codings.

VERSATILE CONFIGURATION OPTIONS

There are 6 sizes, 3 termination types and a great variety of various contact inserts to choose from.

FUNCTIONAL PRINCIPLE OF THE PUSH-PULL LOCKING

Push-Pull locking systems have a highly user-friendly locking mechanism. When the connector is mated with the receptacle, the connector's locking fingers (1) will lock into place in the receptacle and form a dependable connection between both parts. It cannot be separated by pulling on the connector's cable (2). Instead, the connector can easily be separated from the receptacle by pulling on the outer housing (3). Push-pull connectors from ODU are available in 6 different standard sizes with diameters from 6.4 mm to 25 mm.

You can read about the precise functioning of the locking mechanism in the relevant series.

Connector in **mated** condition

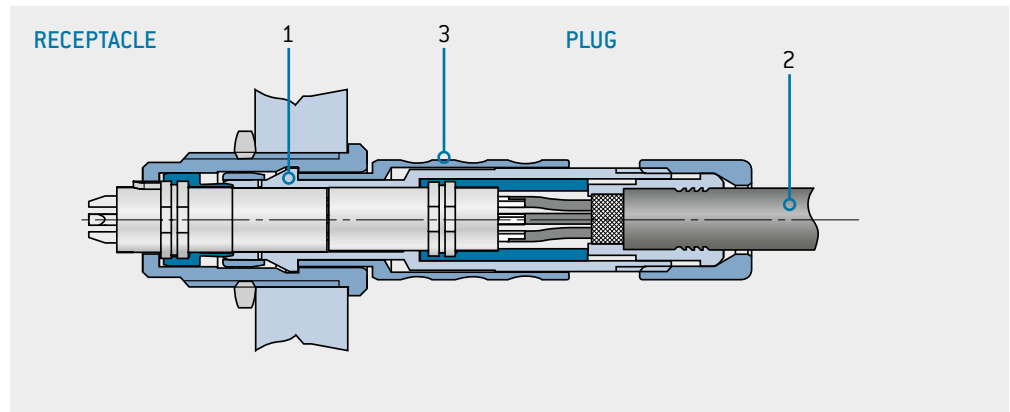

Pulling on the cable or back nut will lock the "fingers" firmly in place in the receptacle's locking groove. This prevents the connector from being disconnected.

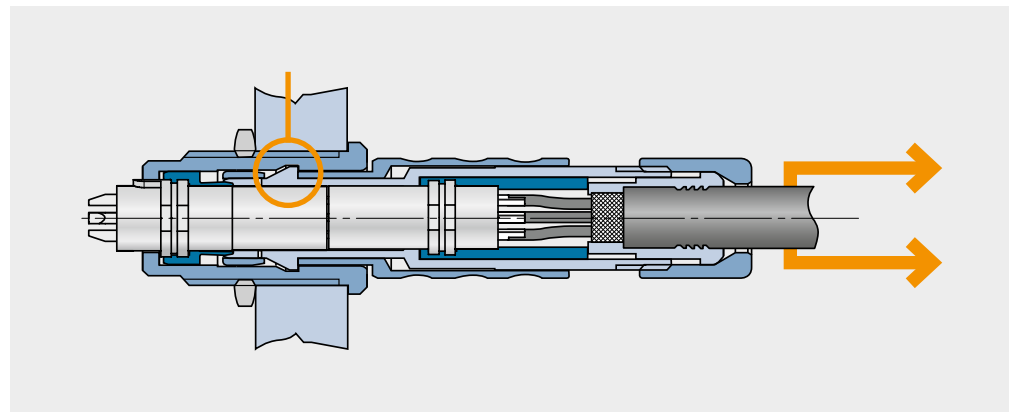

But pulling on the **outer housing** will cause the fingers to emerge from the locking groove, making it easy to disconnect the connector.

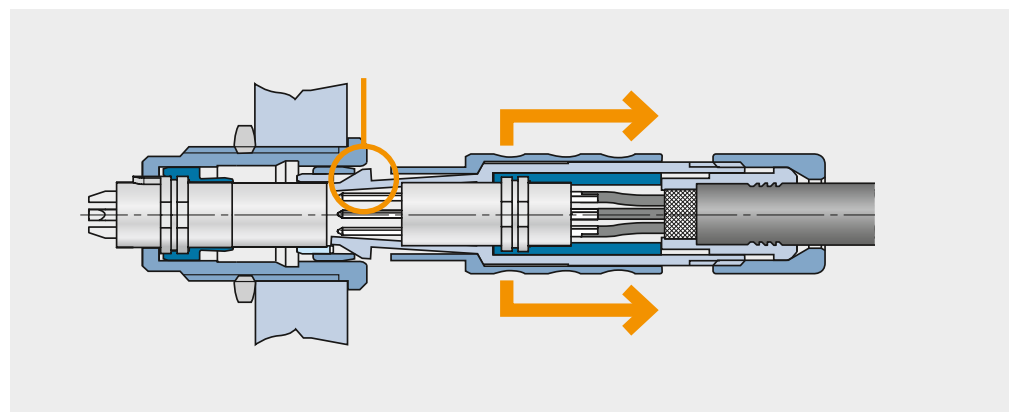

IMPORTANT ISSUES AT A GLANCE

VARIOUS SIZES

- Metal connector plug housing deliverable in 6 sizes
- Outer diameter 6.4 mm to 25 mm
- Number of contacts 2 to 40 contacts, mixed inserts
- IP50 and IP68 are deliverable.

APPLICATIONS AND MATERIALS

The ODU MINI-SNAP® uses PEEK insulator material as a standard feature. Other materials are available upon request. ODU MINI-SNAP® connector plug housings are made of brass, nickel plated and then matt chrome plated. Nickel and tin-nickel plated connector plug housings are available upon request as special materials (not autoclavable). The internal parts are made of nickel-plated brass.

Thanks to its versatility and autoclavability (matt chrome), the ODU MINI-SNAP® is used in a wide range of fields, such as medical technology, measurement and testing technology, military and security technology, industrial electronics and automotive.

The temperature of ODU MINI-SNAP® range under general conditions of use runs from -40 °C to +120 °C, while autoclavable connectors can even be used at temperatures up to +134 °C (see page [170](#)).

TURNUED CONTACTS

Turned contacts are available in diameter 0.5 mm to 2 mm in the following termination types:

Solder, crimp and PCB

Mating cycles	> 5,000
Material	Brass
Plating	Ni and Au

TERMINATION TECHNOLOGIES

	Plug	Receptacle
Crimp termination	•	•
Solder termination	•	•
PCB termination	•	•

STANDARD PIN CONTACTS



Information on diameters, terminal types and current-carrying capacity can be found in the relevant series after the inserts.



ODU MINI-SNAP®



CONFIGURATION GUIDELINE

Correct configuring – step by step

BIT BY BIT TO THE PERFECT CONNECTION

ODU offers you high-quality connectors and comprehensive service for the complete assembly. From connectors to watertight grouting, we provide the complete system from a single source.

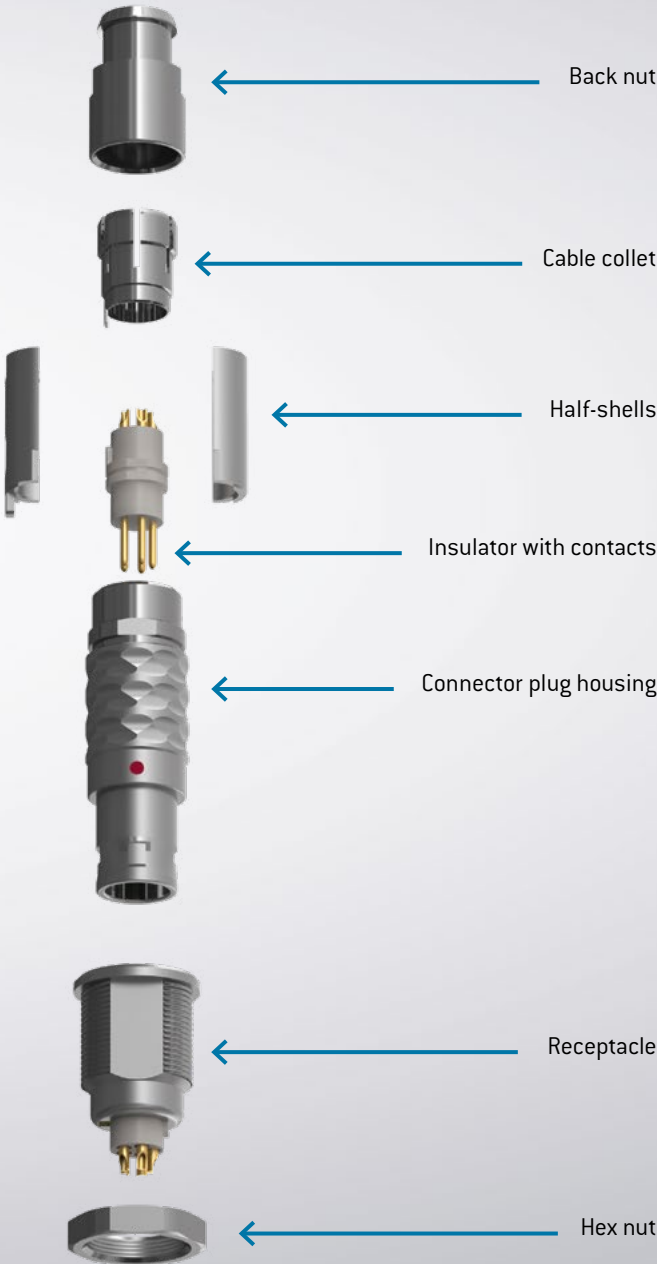

SAMPLE CONFIGURATION STEP BY STEP

The perfect product for you in just a few steps. These step-by-step instructions show you how to configure your own individual product with the ODU part number key based on a sample configuration.



Connector in style 2 / size 2 / series L / keying θ° / connector plug housing Ms matt chrome plated / insulator PEEK / 16 contacts / pin (solder) Au / termination cross-section AWG 22 / cable diameter 6–7.2 mm / back nut for silicone cable bend relief (silicone cable bend relief has to be ordered separately)

STEP 1: SERIES (SEE POSITION 4)

1	2	3	4	5	6	7	8	9	10	11	12	13	14	15	16	17	18	19
			L		C	-	P								-			0

←

SERIES L

STEP 2: STYLE (SEE POSITIONS 1,2 AND 19)

Page [28–38](#) (Series L), [80–87](#) (Series K), [120–124](#) (Series B)

1	2	3	4	5	6	7	8	9	10	11	12	13	14	15	16	17	18	19	
S	2		L		C	-	P								-			0	S

←

STYLE S 2 WITH BACK NUT FOR CABLE BEND RELIEF

STEP 3: SIZE (SEE POSITION 3)

Page [28–38](#) (Series L), [80–87](#) (Series K), [120–124](#) (Series B)

1	2	3	4	5	6	7	8	9	10	11	12	13	14	15	16	17	18	19	
S	2	2	L		C	-	P								-			0	S

←

SIZE 2

STEP 4: KEYING (SEE POSITION 5)

Page [39](#) (Series L), [88](#) (Series K), [125](#) (Series B)

1	2	3	4	5	6	7	8	9	10	11	12	13	14	15	16	17	18	19	
S	2	2	L	0	C	-	P								-			0	S

←

KEYING θ°

STEP 5: HOUSING MATERIAL (SEE POSITION 6)

Page [39](#) (Series L), [88](#) (Series K), [125](#) (Series B)

1	2	3	4	5	6	7	8	9	10	11	12	13	14	15	16	17	18	19	
S	2	2	L	0	C	-	P								-			0	S

←

CR matt

SURFACE MATT CHROMATE (OTHERS UPON REQUEST)



ODU MINI-SNAP®

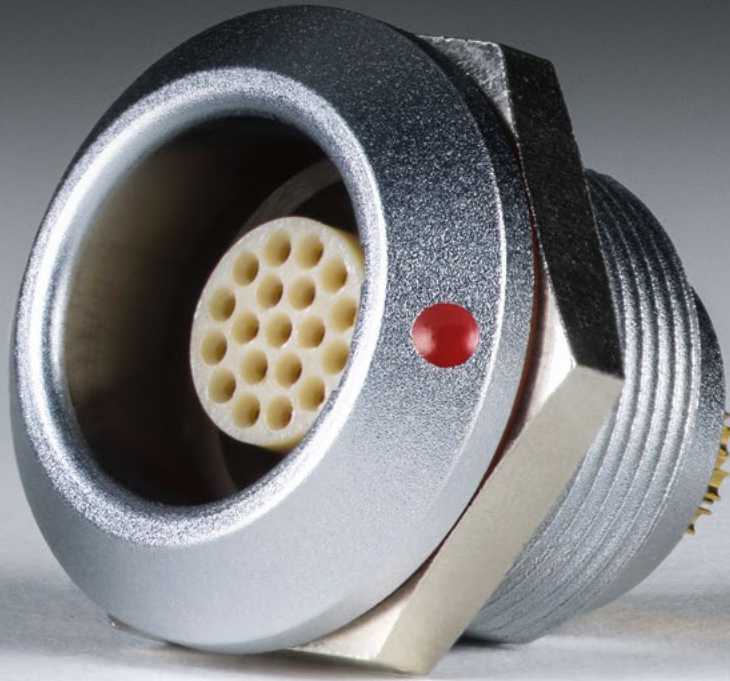

ODU MINI-SNAP® SERIES K

Summary ODU MINI-SNAP® series K	76
The LP locking principle	78
Styles	80
Keyings	88
Contact inserts and PCB Layouts	90
Cable collet system	108
Accessories	110

SUMMARY ODU MINI-SNAP® SERIES K

The ODU MINI-SNAP® Series K is keyed by pin and groove. These Push-Pull circular connectors can be configured in many different ways: a wide variety of sizes and termination types and contact inserts are available.

- Keying over pin and groove
- 2–40 contacts/mixed inserts
- Up to 5 sizes and 3 termination types
- Choice of numerous plugs and receptacles
- IP68
- 5,000 mating cycles and more
- Contacts for solder, crimp and PCB termination





STRAIGHT PLUG		P.80
IP68 ¹		S 1
		S 2
		A 1
		A 2

PANEL-MOUNTED PLUG		P.82
IP68 ¹		A A
IP68 ²		A D

RIGHT-ANGLED PLUG		P.83
IP68 ¹		W 1
		W 2

¹IP68 when mated. ²IP68 when mated or unmated.

IN-LINE RECEPTACLE		P.84
IP68 ¹		K 1
		K 2

RECEPTACLE		P.85
IP68 ¹		G 1
		G 3
		G 4
IP68 ²		G 8
		G L

For assembly instructions, please refer to our website: www.odu-connectors.com/downloads/assembly-instructions

THE LP LOCKING PRINCIPLE SERIES K

Connector
in **unmated** condition

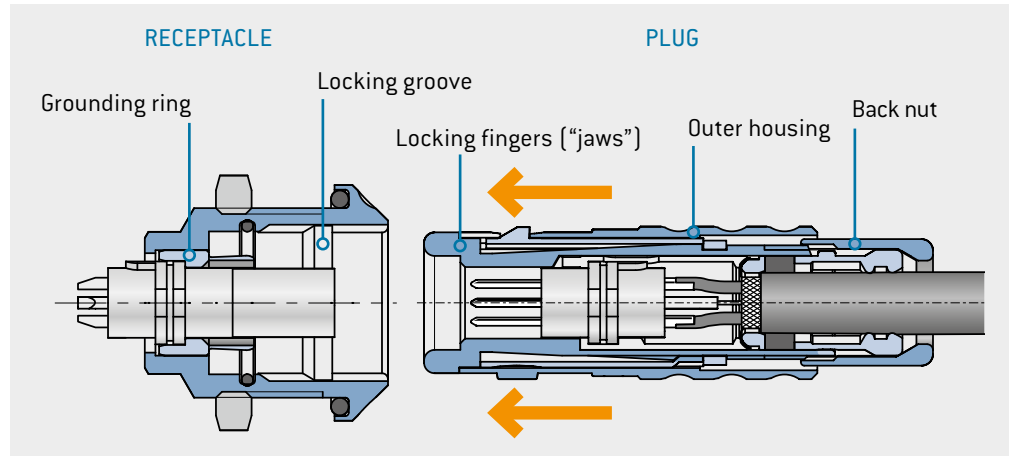

Connector
in **mated** condition

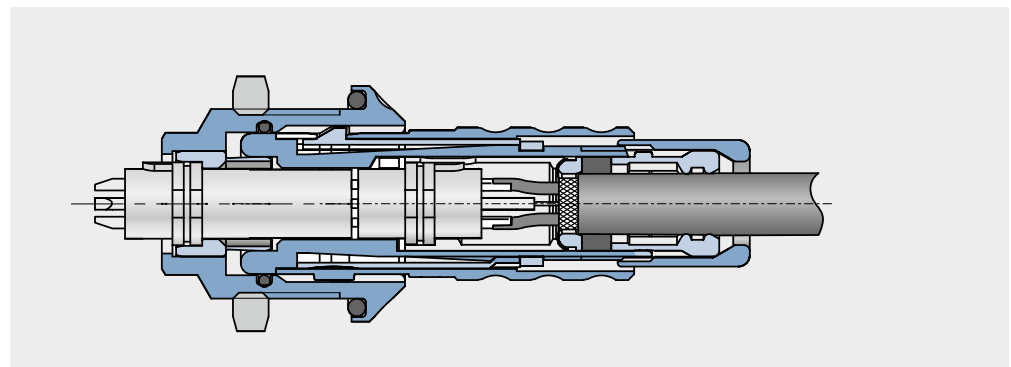

Pulling on the cable or back nut will lock the “fingers” firmly in place in the receptacle’s locking groove. This prevents the connector from being disconnected.

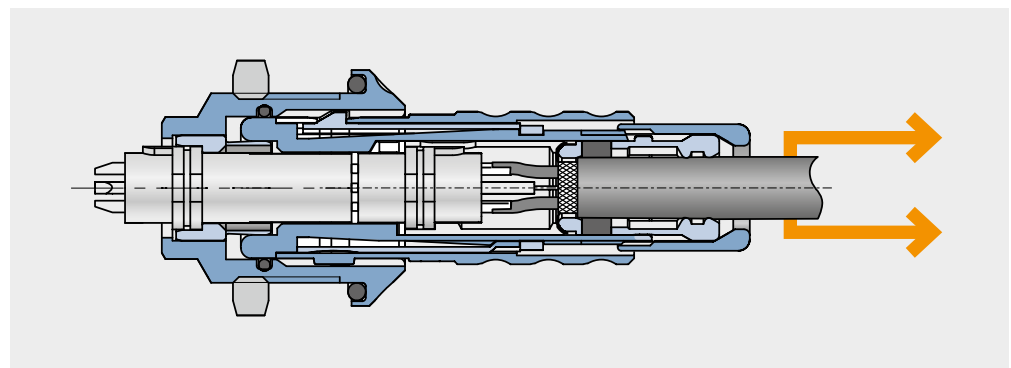

But pulling on the **outer housing** will cause the “fingers” to emerge from the locking groove, making it **easy to disconnect** the connector.

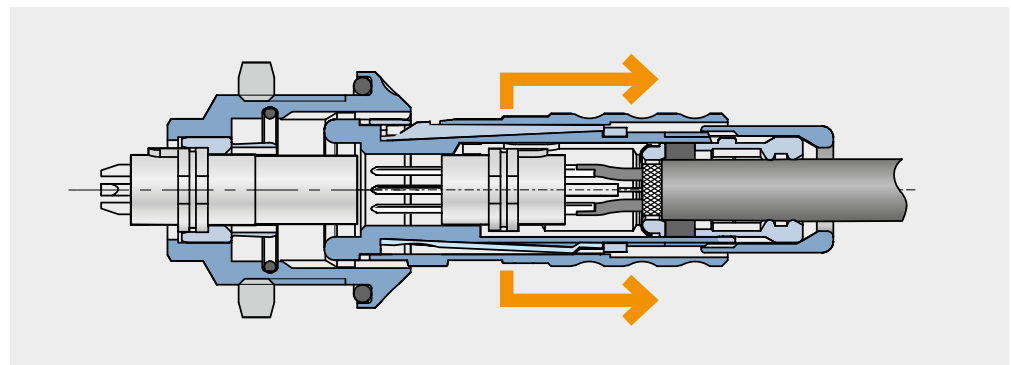

THE LP LOCKING SERIES K IN SECTIONAL VIEW

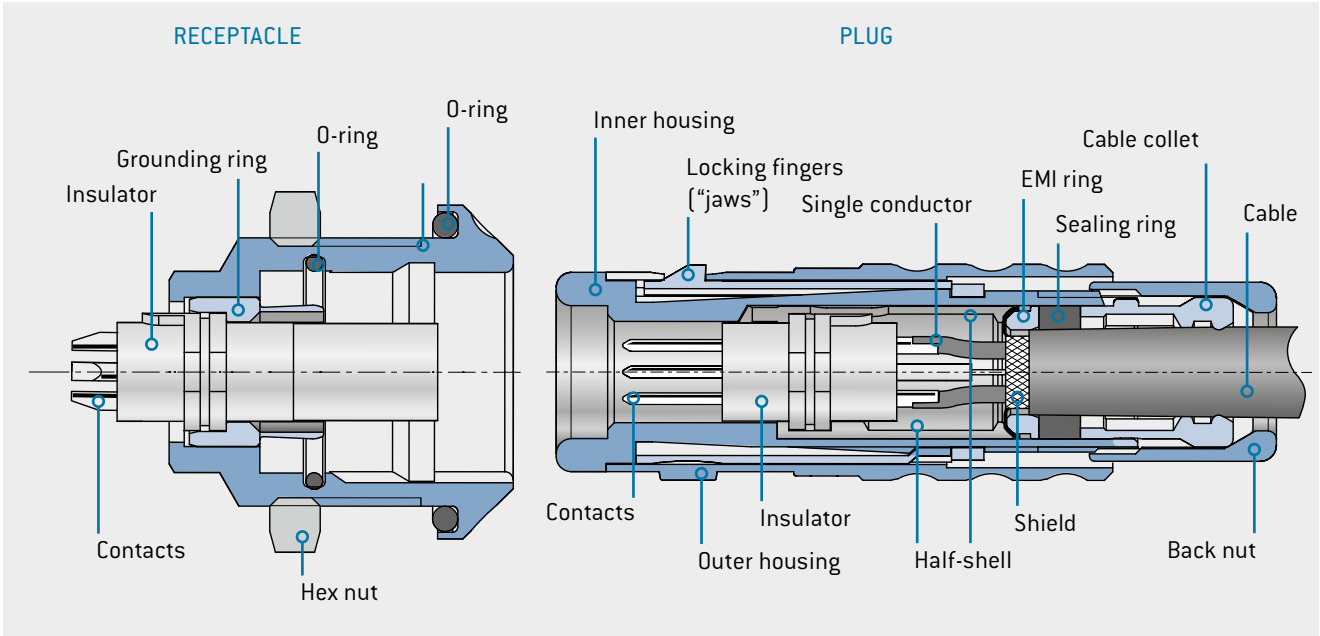

AVAILABLE SIZES

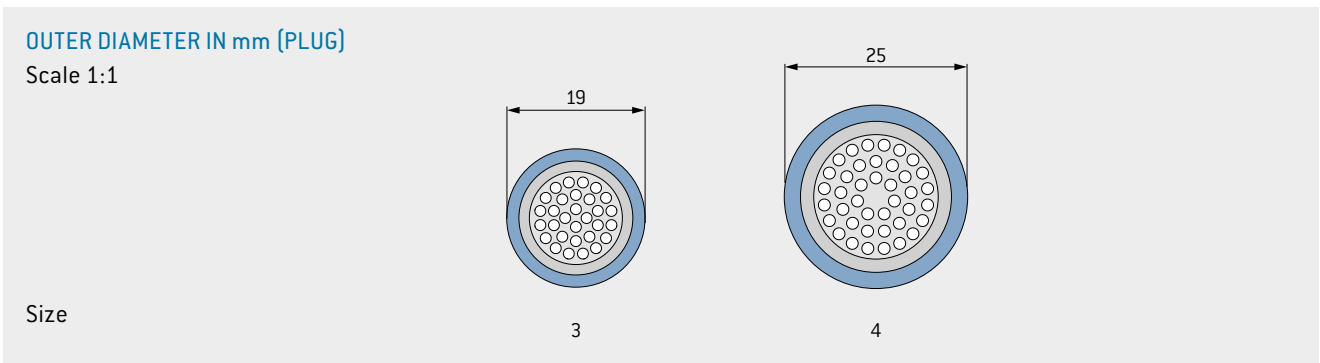
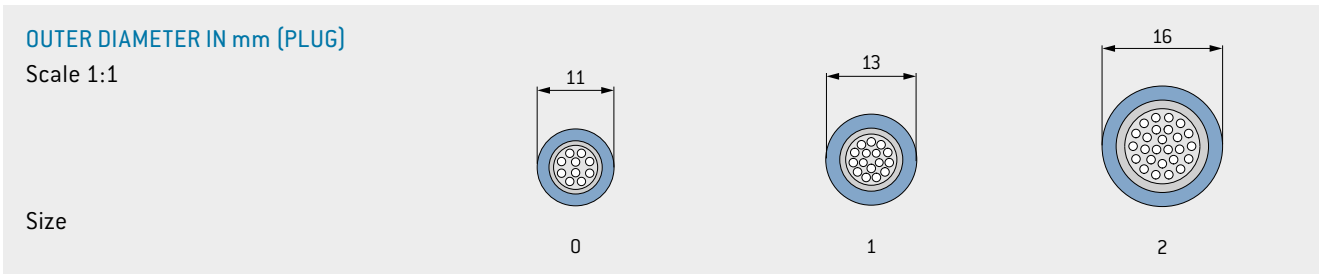

STRAIGHT PLUG



S 1 0 **STYLE: 1** IP68

With standard back nut

S 2 S **STYLE: 2** IP68

With back nut for cable bend relief¹

Size	L1 mm	L2 mm	D mm	S1 SW mm	S2 SW mm
0	≈ 37	≈ 26	11	7	7
1	≈ 44	≈ 30	13	10	10
2	≈ 50	≈ 34	16	12	13
3	≈ 60	≈ 40	19	14	15
4	≈ 73	≈ 52	25	20	20

TECHNICAL DATA

- IP68 in mated condition.
- Contact configuration from page 90.

0 1 2 3 4

1 2 3 4 5 6 7 8 9 10 11 12 13 14 15 16 17 18 19

K C - P - 0

¹Please order cable bend reliefs separately, see page 111.

BREAK-AWAY CONNECTOR



A 1 **0** **STYLE: 1** **IP68**

With standard back nut

A 2 **S** **STYLE: 2** **IP68**

With back nut for cable bend relief¹

Size	L1 mm	L2 mm	D mm	A1 SW mm	A2 SW mm
0	≈ 37	≈ 26	11	7	7
1	≈ 44	≈ 30	13	10	10
3	≈ 60	≈ 40	19	14	15

TECHNICAL DATA

- IP68 in mated condition.
- Contact configuration from page 90.
- Plug can be separated by pulling on the cable.

0 1 3

1 2 3 4 5 6 7 8 9 10 11 12 13 14 15 16 17 18 19

K C - P - 0

¹ Please order cable bend reliefs separately, see page 111.

PANEL-MOUNTED PLUG

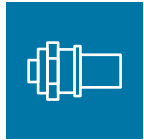

Suitable for creating a docking connection between 2 devices (e.g. a charging station).

A A

STYLE: A

With hex nut, without locking, installation from front of panel

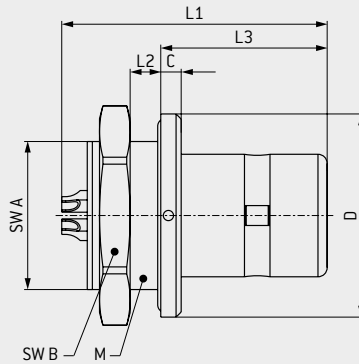

IP68

Panel cut-out

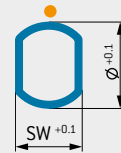

● Keying indication

Size	L1 ¹ mm	L2 mm	L3 mm	M mm	C mm	D mm	SW A mm	SW B mm	Panel cut-out	
									SW mm	Ø mm
1	28	≈ 4	16.3	16 × 1	2	20	14.5	18.5	14.6	16.1
2	32	≈ 4.5	19	20 × 1	2.7	25	18.5	25	18.6	20.1

TECHNICAL DATA

- IP68 in mated condition.
- Anti-rotation feature.
- Contact configuration from page 90.
- PCB layouts, see page 91.

1
2

A D

STYLE: D

With hex nut, without locking, installation from front of panel

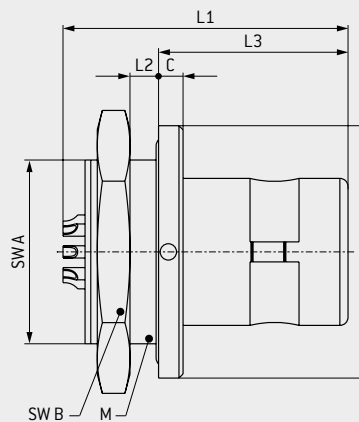
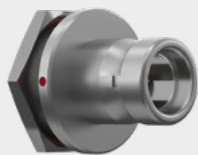

IP68

Panel cut-out

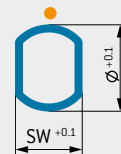

● Keying indication

Size	L1 ¹ mm	L2 mm	L3 mm	M mm	C mm	D mm	SW A mm	SW B mm	Panel cut-out	
									SW mm	Ø mm
3	36	≈ 4	23.2	24 × 1	3	31	22.5	30	22.6	24.1

TECHNICAL DATA

- IP68 in mated and unmated condition.
- Anti-rotation feature.
- No crimp contact possible.
- Contact configuration from page 90.
- PCB layouts, see page 91.

3

1 2 3 4 5 6 7 8 9 10 11 12 13 14 15 16 17 18 19

K C - P - 0

¹ L1 = maximum length including contact insert.

IN-LINE RECEPTACLE

Suitable for creating a cable-cable connection.

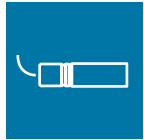

K 1

0

STYLE: 1

IP68

With standard back nut

K 2

S

STYLE: 2

IP68

With back nut for cable bend relief¹

Size	L1 mm	D mm	SW A mm	K1 SW B mm	K2 SW B mm
0	≈ 39	13	9	7	7
1	≈ 47	15	11	10	10
2	≈ 54	19	14	12	13
3	≈ 64	23	16.5	14	15
4	≈ 79	29	22	20	20

TECHNICAL DATA

- IP68 in mated condition.
- Contact configuration from page 90.

1

2

3

4

5

6

7

8

9

10

11

12

13

14

15

16

17

18

19

K

C

-

P

-

0

¹ Please order cable bend reliefs separately, see page 111.

RECEPTACLE



G 1

STYLE: 1

Receptacle for installation from front of panel

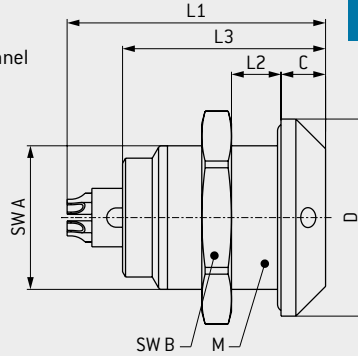

IP68

Panel cut-out

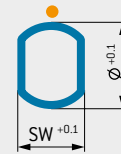

● Keying indication

Size	L1 ¹ mm	L2 mm	L3 ² mm	M mm	D mm	SW A mm	SW B mm	C mm	Panel cut-out	
									SW mm	Ø mm
0	≈ 21	≈ 5.5	15.5	14 × 1	18	12.5	17	4	12.6	14.1
1	≈ 28	≈ 9	20.5	16 × 1	20	14.5	19	4.5	14.6	16.1
2	≈ 31	≈ 9	23	20 × 1	25	18.5	24	5	18.6	20.1
3	≈ 36	≈ 11	28	24 × 1	31	22.5	30	6	22.6	24.1
4	≈ 40	≈ 11	31.5	30 × 1	37	28.5	36	6.5	28.6	30.1

TECHNICAL DATA

- IP68 in mated condition.
- Anti-rotation feature.
- Contact configuration from page 90.
- PCB layouts, see page 91.
- Only straight PCB contact possible.

G 3

STYLE: 3

Receptacle with slotted mounting nut, installation from rear of panel

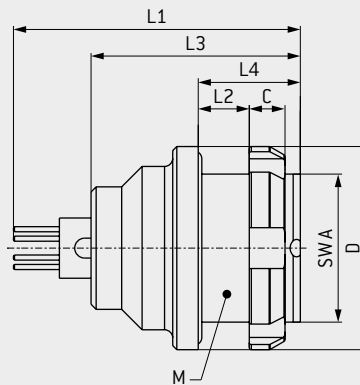

IP68

Panel cut-out

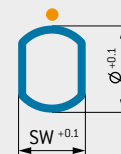

● Keying indication

Size	L1 ¹ mm	L2 mm	L3 ² mm	L4 mm	M mm	D mm	C mm	SW A mm	Panel cut-out	
									SW mm	Ø mm
0	≈ 21	≈ 3	15.5	7	14 × 1	18	4	12.5	12.6	14.1
1	≈ 28	≈ 6	20.5	10	16 × 1	20	3.5	14.5	14.6	16.1
2	≈ 31	≈ 6	23	10	20 × 1	25	3.5	18.5	18.6	20.1
3 ³	≈ 36	≈ 7.5	28	12	24 × 1	31	4.5	22.5	22.6	24.1
4	≈ 40	≈ 6.5	31.5	13.5	30 × 1	41.5	7	28.5	28.6	30.1

TECHNICAL DATA

- IP68 in mated condition.
- Anti-rotation feature.
- Contact configuration from page 90.
- Assembly wrench, see page 158.
- Right-angled PCB contact possible.
- PCB layouts, see page 91.

1 2 3 4 5 6 7 8 9 10 11 12 13 14 15 16 17 18 19

K C - P - 0 0

¹ L1 = maximum length including contact insert. ² L3 = length of connector plug housing. ³ Note: size 3 with round nut.

RECEPTACLE

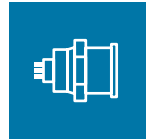

G 4

STYLE: 4

Installation from front of panel with low installation depth

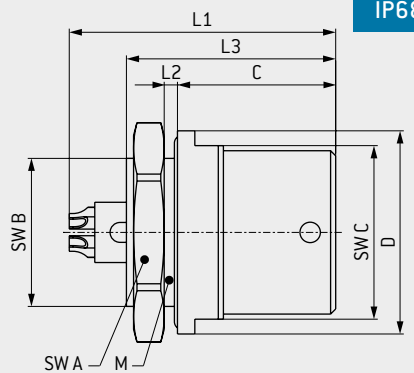

IP68

Panel cut-out

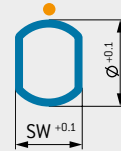

● Keying indication

Size	L1 ¹ mm	L2 mm	L3 ² mm	M mm	D mm	SW A mm	SW B mm	SW C mm	C mm	Panel cut-out	
										SW mm	Ø mm
1	≈ 28	≈ 1.5	20.5	16 × 1	20	19	14.5	17	15.5	14.6	16.1
2	≈ 31	≈ 2	23	20 × 1	25	24	18.5	20	17	18.6	20.1

1
2

TECHNICAL DATA

- IP68 in mated condition.
- Anti-rotation feature.
- Contact configuration from page 90.
- PCB layouts, see page 91.
- Only straight PCB contact possible.

G 8

STYLE: 8

With slotted mounting nut, installation from rear of panel

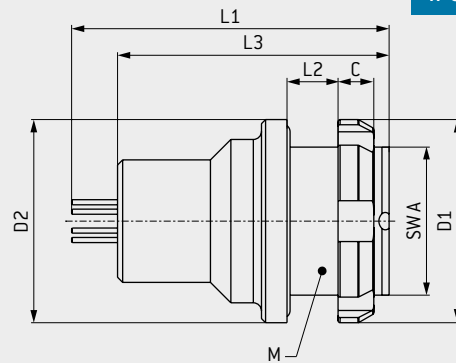

IP68³

Panel cut-out



● Keying indication

Size	L1 ¹ mm	L2 mm	L3 ² mm	M mm	D 1 mm	D 2 mm	SW A mm	C mm	Panel cut-out	
									SW mm	Ø mm
1	≈ 32	≈ 6	26.6	16 × 1	20	20	14.5	3.5	14.6	16.1
2	≈ 34	≈ 6	27	20 × 1	25	25	18.5	3.5	18.6	20.1
3 ⁴	≈ 39	≈ 7	32.7	24 × 1	30	31	22.5	4.5	22.6	24.1
4	≈ 42	≈ 6	35.5	30 × 1	41.5	37	28.5	7	28.6	30.1

1
2
3
4

TECHNICAL DATA

- IP68 in mated and unmated condition.
- Anti-rotation feature.
- No crimp contact possible.
- Contact configuration from page 90.
- Right-angled PCB contact possible, see page 106.
- Note: assembly wrench, see page 158.

1 2 3 4 5 6 7 8 9 10 11 12 13 14 15 16 17 18 19

K C - P - 0 0

¹ L1 = maximum length including contact insert. ² L3 = length of connector plug housing. ³ Note: tight, grouted receptacle, see page 163. ⁴ Note: size 3 with round nut.

RECEPTACLE



G L

STYLE: L

IP68³

Installation from front of panel

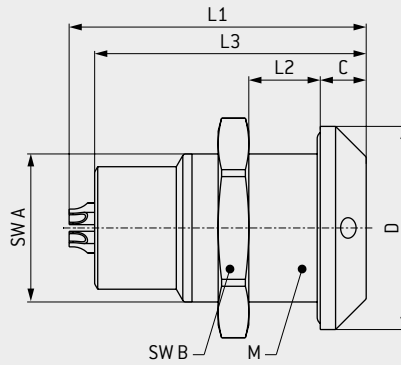

Panel cut-out

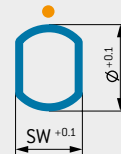

● Keying indication

Size	L1 ¹ mm	L2 mm	L3 ² mm	M mm	D mm	C mm	SW A mm	SW B mm	Panel cut-out	
									SW mm	Ø mm
0	≈ 24	≈ 5	19.7	14 × 1	18	4	12.5	17	12.6	14.1
1	≈ 32	≈ 9	26.6	16 × 1	20	4.5	14.5	19	14.6	16.1
2	≈ 34	≈ 9	27	20 × 1	25	5	18.5	24	18.6	20.1

TECHNICAL DATA

- IP68 in mated and unmated condition.
- Anti-rotation feature.
- Contact configuration from page 90.
- No crimp contact possible.
- Only straight PCB contact possible.

0
1
2

1 2 3 4 5 6 7 8 9 10 11 12 13 14 15 16 17 18 19

K C - P - 0 0

¹ L1 = maximum length including contact insert. ² L3 = length of connector plug housing. ³ Note: tight, grouted receptacle, see page 163.

KEYINGS

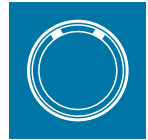

	Angle	Receptacle front view	Size				
			0	1	2	3	4
Ø	0°		•	•	•	•	•
A	30°		•	•	•	•	o
C	45°		•	•	•	o	o
F	60°		•	•	•	o	o
H	75°		o	o	o	o	o
K	95°		o	o	o	o	o
Q	120°		o	o	o	o	o
W	145°		o	o	o	o	o

	Housing material	
C	Standard	Cu-alloy / matt chromate
Z	On request	Cu-alloy / tin-nickel

Special materials and surfaces on request.

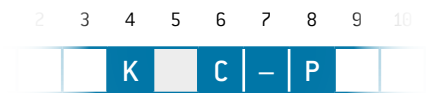

• Standard
o On request

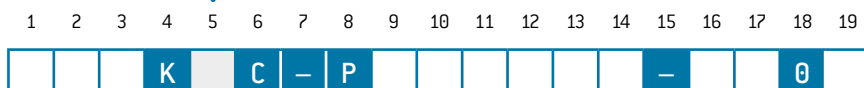
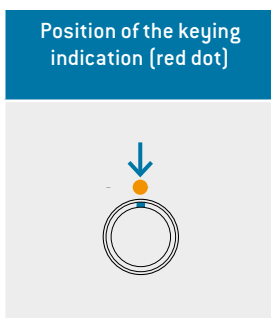

FOR YOUR NOTES

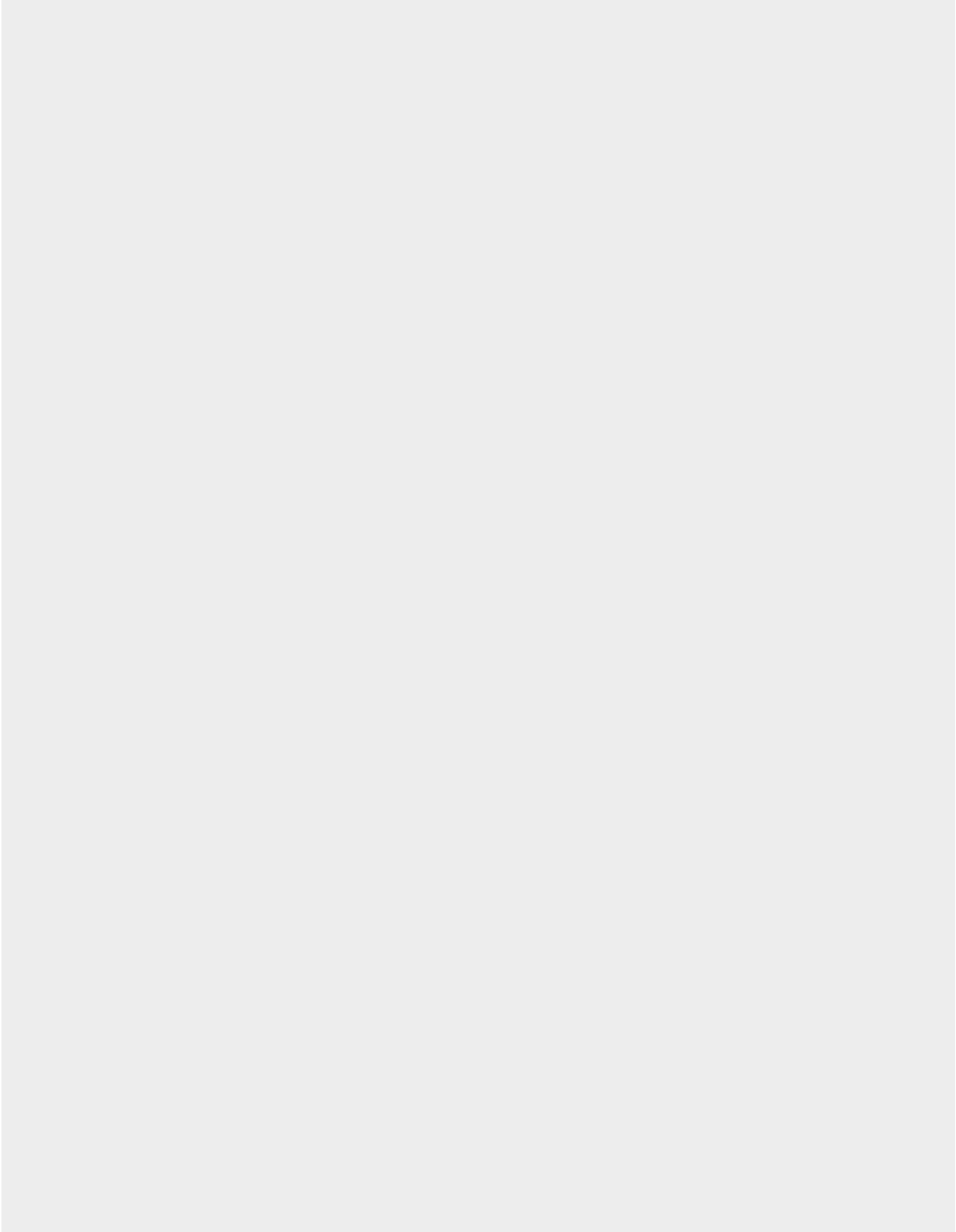

PCB LAYOUTS

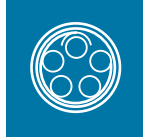

For PCB contacts (Size 0).

	Straight	90° right-angled		Straight	90° right-angled
2 contacts	<p>Contact borehole: $\varnothing 0.8$ mm</p>	<p>Contact borehole: $\varnothing 0.7$ mm</p>	7 contacts	<p>Contact borehole: $\varnothing 0.6$ mm</p>	<p>Contact borehole: $\varnothing 0.7$ mm</p>
3 contacts	<p>Contact borehole: $\varnothing 0.8$ mm</p>	<p>Contact borehole: $\varnothing 0.7$ mm</p>	9 contacts	<p>Contact borehole: $\varnothing 0.6$ mm</p>	<p>Contact borehole: $\varnothing 0.6$ mm</p>
4 contacts	<p>Contact borehole: $\varnothing 0.6$ mm</p>	<p>Contact borehole: $\varnothing 0.7$ mm</p>	10 contacts	<p>Contact borehole: $\varnothing 0.6$ mm</p>	<p>Contact borehole: $\varnothing 0.7$ mm</p>
5 contacts	<p>Contact borehole: $\varnothing 0.6$ mm</p>	<p>Contact borehole: $\varnothing 0.7$ mm</p>	High-speed version		
6 contacts	<p>Contact borehole: $\varnothing 0.6$ mm</p>	<p>Contact borehole: $\varnothing 0.7$ mm</p>	4 contacts	<p>Contact borehole: $\varnothing 0.6$ mm</p>	<p>Contact borehole: $\varnothing 0.7$ mm</p>

All specifications are only valid for socket inserts.
Pin inserts on request. Further PCB layouts upon request.

CONTACT INSERTS (SIZE 1)



Number of contacts		Contact type			Part number key			Contact diameter mm	Single contact nominal current ¹ A	Clearance and creepage distance		Test voltage ² kVeff	Nominal voltage ⁵ kVrms	Termination diameter mm	Termination cross-section		View on termination area	
		Termination	Socket	Pin						Contact to contact mm	Contact to housing mm				mm	AWG	mm ²	Pin piece
0	2	Solder	L	M	P	N	0	1.3	14	1	0.7	1.650	0.550	1.4	18	1		
			P	H	0	11	20		0.5									
		Crimp ³	N	P	P	L	0		14					–	18–20	1.00–0.50		
			PCB ⁴	Q	R	P	0		0					11	0.7	–		
0	3	Solder		L	M	P	N	0	1.3	14	0.8	0.6	1.000	0.333	1.4	18	1.00	
			P	H	0	11	0.9	0.7		1.500	0.500	1.1	20	0.50				
		Crimp ³	N	P	P	L	0	14		0.8	0.6	1.000	0.333	–	18–20	1.00–0.50		
			PCB ⁴	Q	R	P	0	0		14	0.9	0.7	1.500	0.500	0.7	–	–	
0	4	Solder		L	M	J	G	0	0.9	7.5	1	1.1	1.500	0.500	0.85	22	0.38	
			J	H	0	9	0.7	0.8		1.000	0.333	–	20–24	0.50–0.25				
		Crimp ³	N	P	J	G	0	7.5		1	1.1	1.500	0.500	0.7	–	–		
PCB ⁴	Q		R	J	0	0	9	0.6	0.6	1.000	0.333	1.1	20	0.50				
	J	H	0	7.5	0.9	0.9	1.350	0.450	0.85	22	0.38							
0	5	Solder	L	M	J	H	0	0.9	9	0.6	0.6	1.000	0.333	1.1	20	0.50		
			J	G	0	7.5	0.9		0.9	1.350	0.450	0.85	22	0.38				
		Crimp ³	N	P	J	H	0		9	0.6	0.6	1.000	0.333	–	20–24	0.50–0.25		
			PCB ⁴	Q	R	J	G		0	7.5	0.9	0.9	1.350	0.450	–	22–26		
0	6	Solder		L	M	F	G	0	0.7	7.5	0.7	0.7	1.000	0.333	0.85	22	0.38	
			F	D	0	5	0.9	0.9		1.200	0.400	0.65	26	0.15				
		Crimp ³	N	P	F	G	0	7.5		0.7	0.7	1.000	0.333	–	22–26	0.38–0.15		
			PCB ⁴	Q	R	F	C	0		5	0.9	0.9	1.200	0.400	–	28–32	0.09–0.04	
													0.5	–	–			

¹ Derating factor, see page 167.

² SAE AS 13441:2004 method 3001.1.

³ Tools for crimping and adjustment dimensions for crimping tool, see page 156.

⁴ PCB layouts, see page 93. PCB termination only possible in the receptacle and panel-mounted plug

⁵ Max. operating voltage at NN (sea level) acc. to SAE AS 13441:2004 method 3001.1. Further information on page 168..

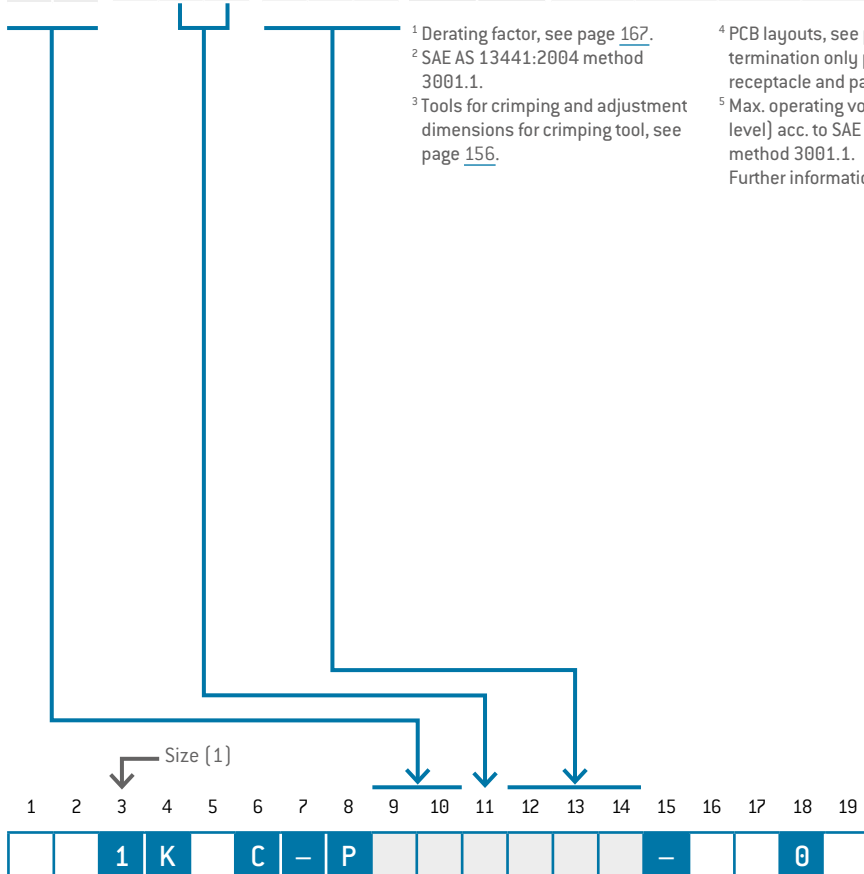

PCB LAYOUTS



For PCB contacts (Size 1).

	Straight	90° right-angled
2 contacts	<p>Contact borehole: $\varnothing 0.8$ mm</p>	<p>Contact borehole: $\varnothing 0.9$ mm</p>
3 contacts	<p>Contact borehole: $\varnothing 0.8$ mm</p>	<p>Contact borehole: $\varnothing 0.9$ mm</p>
4 contacts	<p>Contact borehole: $\varnothing 0.8$ mm</p>	<p>Contact borehole: $\varnothing 0.7$ mm</p>
5 contacts	<p>Contact borehole: $\varnothing 0.8$ mm</p>	<p>Contact borehole: $\varnothing 0.7$ mm</p>
6 contacts	<p>Contact borehole: $\varnothing 0.6$ mm</p>	<p>Contact borehole: $\varnothing 0.7$ mm</p>

All specifications are only valid for socket inserts.
Pin inserts on request. Further PCB layouts upon request.

CONTACT INSERTS (SIZE 1)

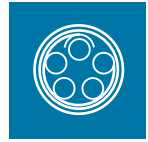

Number of contacts	Contact type			Part number key			Contact diameter mm	Single contact nominal current ¹ A	Clearance and creepage distance		Test voltage ² kVeff	Nominal voltage ⁵ kVrms	Termination diameter mm	Termination cross-section		View on termination area	
	Termination	Socket	Pin	F	G	Ø			Contact to contact mm	Contact to housing mm				AWG	mm ²	Pin piece	Socket piece
0	Solder	L	M	F	G	Ø	0.7	7.5	0.7	0.7	1.000	0.333	0.85	22	0.38		
				F	D	Ø		5	0.9	0.9	1.200	0.400					
	Crimp ³	N	P	F	G	Ø		7.5	0.7	0.7	1.000	0.333	–	22-26	0.38-0.15		
				F	C	Ø		5	0.9	0.9	1.200	0.400	–	28-32	0.09-0.04		
0	Solder	L	M	F	G	Ø	0.7	7.5	0.4	0.6	0.900	0.300	0.85	22	0.38		
				F	D	Ø		5	0.6	0.8	1.000	0.333					
	Crimp ³	N	P	F	G	Ø		7.5	0.4	0.6	0.900	0.300	–	22-26	0.38-0.15		
				F	C	Ø		5	0.6	0.8	1.000	0.333	–	28-32	0.09-0.04		
1	Solder	L	M	C	D	Ø	0.5	5	0.3	0.7	0.600	0.200	0.65	26	0.15		
				C	C	Ø		4	0.5	0.9	1.000	0.333					
	Crimp ³	N	P	F	G	Ø		7.5	0.4	0.6	0.900	0.300	–	22-26	0.38-0.15		
				F	C	Ø		5	0.6	0.8	1.000	0.333	–	28-32	0.09-0.04		
1	Solder	L	M	C	C	Ø	0.5	5	0.3	0.7	0.600	0.200	0.65	26	0.15		
				C	C	Ø		4	0.5	0.9	1.000	0.333					
	Crimp ³	N	P	F	G	Ø		7.5	0.4	0.6	0.900	0.300	–	22-26	0.38-0.15		
				F	C	Ø		5	0.6	0.8	1.000	0.333	–	28-32	0.09-0.04		
1	Solder	L	M	C	C	Ø	0.5	5	0.3	0.7	0.600	0.200	0.65	26	0.15		
				C	C	Ø		4	0.5	0.9	1.000	0.333					
	Crimp ³	N	P	F	G	Ø		7.5	0.4	0.6	0.900	0.300	–	22-26	0.38-0.15		
				F	C	Ø		5	0.6	0.8	1.000	0.333	–	28-32	0.09-0.04		
1	Solder	L	M	C	C	Ø	0.5	5	0.3	0.7	0.600	0.200	0.65	26	0.15		
				C	C	Ø		4	0.5	0.9	1.000	0.333					
	Crimp ³	N	P	F	G	Ø		7.5	0.4	0.6	0.900	0.300	–	22-26	0.38-0.15		
				F	C	Ø		5	0.6	0.8	1.000	0.333	–	28-32	0.09-0.04		

SPECIFIC INSERTS FOR HIGH DATA TRANSMISSION RATES

0	4	Solder	L	M	J	G	Ø	0.9	7.5	1	1.1	1.500	0.500	0.85	22	0.38			Ethernet ^{6,7} Type CAT 5 ⁷ up to 100 Mbit
		Crimp ³	N	P	J	G	Ø							–	22-26	0.38-0.15			
		Print ⁴	Q	R	J	Ø	Ø							0.7	–	–			
D	8	Solder	L	M	C	D	Ø	0.5	4	0.5	0.7	1.000	0.333	0.65	26	0.15			Ethernet ^{6,7} Type CAT 5 ⁷ up to 1 Gbit
		Print ⁴	Q	R	C	Ø	Ø							0.5	–	–			

¹ Derating factor, see page 167.

² SAE AS 13441:2004 method 3001.1.

³ Tools for crimping and adjustment dimensions for crimping tool, see page 156.

⁴ PCB layouts, see page 95. PCB termination only possible in the receptacle and panel-mounted plug

⁵ Max. operating voltage at NN (sea level) acc. to SAE AS 13441:2004 method 3001.1.

Further information on page 168.

⁶ ISO/IEC 11801:2017.

Further information on request.

⁷ Concerning data transmission protocols please note page 2.

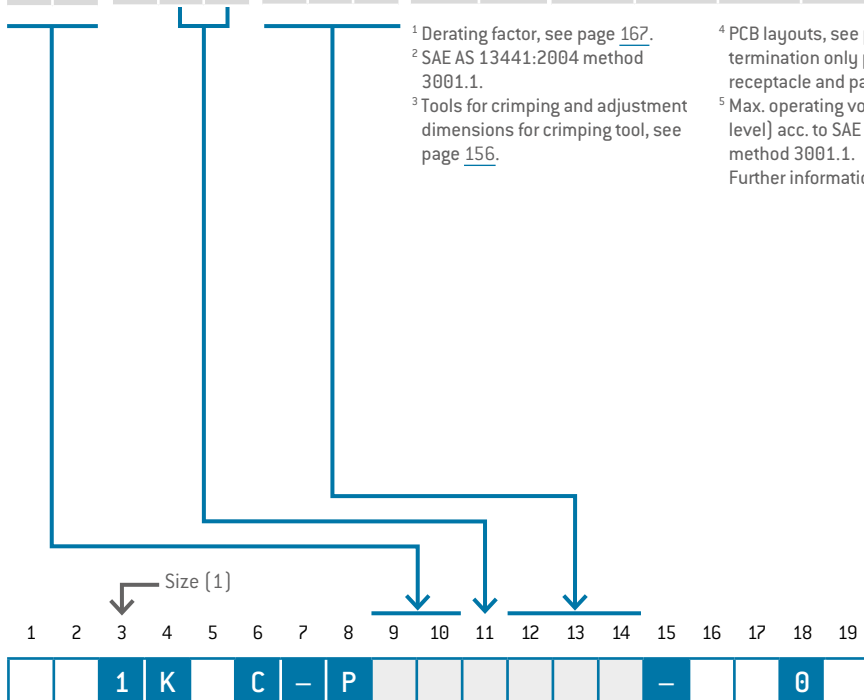

PCB LAYOUTS

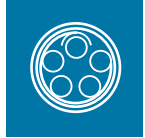

For PCB contacts (Size 1).

	Straight	90° right-angled	Straight	90° right-angled	
7 contacts	<p>Contact borehole: $\varnothing 0.6$ mm</p>	<p>Contact borehole: $\varnothing 0.7$ mm</p>	16 contacts	<p>Contact borehole: $\varnothing 0.6$ mm</p>	<p>Contact borehole: $\varnothing 0.7$ mm</p>
8 contacts	<p>Contact borehole: $\varnothing 0.6$ mm</p>	<p>Contact borehole: $\varnothing 0.7$ mm</p>	High-speed versions		
10 contacts	<p>Contact borehole: $\varnothing 0.6$ mm</p>	<p>Contact borehole: $\varnothing 0.7$ mm</p>	4 contacts	<p>Contact borehole: $\varnothing 0.8$ mm</p>	<p>Contact borehole: $\varnothing 0.7$ mm</p>
14 contacts	<p>Contact borehole: $\varnothing 0.6$ mm</p>	<p>Contact borehole: $\varnothing 0.7$ mm</p>	8 contacts	<p>Contact borehole: $\varnothing 0.6$ mm</p>	

All specifications are only valid for socket inserts.
Pin inserts on request. Further PCB layouts upon request.

PCB LAYOUTS

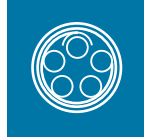

For PCB contacts (Size 2).

	Straight	90° right-angled		Straight	90° right-angled
2 contacts	<p>Contact borehole: $\varnothing 0.8$ mm</p>	<p>Contact borehole: $\varnothing 0.9$ mm</p>		<p>Contact borehole: $\varnothing 0.8$ mm</p>	<p>Contact borehole: $\varnothing 0.9$ mm</p>
3 contacts	<p>Contact borehole: $\varnothing 0.8$ mm</p>	<p>Contact borehole: $\varnothing 0.9$ mm</p>		<p>Contact borehole: $\varnothing 0.8$ mm</p>	<p>Contact borehole: $\varnothing 0.9$ mm</p>
4 contacts	<p>Contact borehole: $\varnothing 0.8$ mm</p>	<p>Contact borehole: $\varnothing 0.9$ mm</p>		<p>Contact borehole: $\varnothing 0.8$ mm</p>	<p>Contact borehole: $\varnothing 0.7$ mm</p>
5 contacts	<p>Contact borehole: $\varnothing 0.8$ mm</p>	<p>Contact borehole: $\varnothing 0.9$ mm</p>			
6 contacts	<p>Contact borehole: $\varnothing 0.8$ mm</p>	<p>Contact borehole: $\varnothing 0.9$ mm</p>			

All specifications are only valid for socket inserts.
Pin inserts on request. Further PCB layouts upon request.

PCB LAYOUTS



For PCB contacts (Size 3).

	Straight	90° right-angled		Straight	90° right-angled
3 contacts	<p>Contact borehole: $\varnothing 0.7$ mm</p>	<p>Contact borehole: $\varnothing 0.9$ mm</p>	14 contacts	<p>Contact borehole: $\varnothing 0.8$ mm</p>	<p>Contact borehole: $\varnothing 0.7$ mm</p>
4 contacts	<p>Contact borehole: $\varnothing 0.8$ mm</p>				
7 contacts	<p>Contact borehole: $\varnothing 0.8$ mm</p>	<p>Contact borehole: $\varnothing 0.9$ mm</p>			
8 contacts	<p>Contact borehole: $\varnothing 0.8$ mm</p>	<p>Contact borehole: $\varnothing 0.9$ mm</p>			
10 contacts	<p>Contact borehole: $\varnothing 0.8$ mm</p>	<p>Contact borehole: $\varnothing 0.9$ mm</p>			

All specifications are only valid for socket inserts.
Pin inserts on request. Further PCB layouts upon request.

PCB LAYOUTS



For PCB contacts (Size 3).

	Straight	90° right-angled	Straight	90° right-angled
16 contacts	<p>Contact borehole: $\varnothing 0.8$ mm</p>	<p>Contact borehole: $\varnothing 0.7$ mm</p>	<p>Contact borehole: $\varnothing 0.6$ mm</p>	<p>Contact borehole: $\varnothing 0.7$ mm</p>
18 contacts	<p>Contact borehole: $\varnothing 0.8$ mm</p>	<p>Contact borehole: $\varnothing 0.7$ mm</p>	<p>Contact borehole: $\varnothing 0.6$ mm</p>	<p>Contact borehole: $\varnothing 0.7$ mm</p>
20 contacts	<p>Contact borehole: $\varnothing 0.6$ mm</p>	<p>Contact borehole: $\varnothing 0.7$ mm</p>	<p>Contact borehole: $\varnothing 0.6$ mm</p>	<p>Contact borehole: $\varnothing 0.7$ mm</p>

All specifications are only valid for socket inserts.
Pin inserts on request. Further PCB layouts upon request.

CONTACT INSERTS (SIZE 4)



Number of contacts		Contact type			Part number key			Contact diameter mm	Single contact nominal current ¹ A	Clearance and creepage distance		Test voltage ² kVeff	Nominal voltage ⁵ kVrms	Termination diameter mm	Termination cross-section		View on termination area	
		Termination	Socket	Pin						Contact to contact mm	Contact to housing mm				AWG	mm ²	Pin piece	Socket piece
0	7 ⁵	Solder	L	M	T	S	9	2	22.5	1.5	1	1.350	0.450	2.40	14	2.50		
			T	0	9	17.5	2.1		1.6	1.650	0.550	1.85	16	1.5				
		PCB ³	Q	R	T	0	9	0.7	-	-	-	-	-	-				
3	0 ⁵	Solder	L	M	J	G	0	0.9	7.5	0.8	1	1.575	0.520	0.85	22	0.38		
			PCB ³	Q	R	J	0							0	0.5	-		
4	0	Solder	L	M	F	G	0	0.7	7.5	0.6	0.8	0.900	0.300	0.85	22	0.38		
			F	D	0	5	0.8		1	1.000	0.333	0.6	26	0.15				
		PCB ³	Q	R	F	0	0	0.5	-	-	-	-	-					

¹ Derating factor, see page 167.

² SAE AS 13441:2004 method 3001.1.

³ PCB layouts, see page 105.

⁴ Max. operating voltage at NN (sea level) acc. to SAE AS 13441:2004 method 3001.1.

Further information on page 168.

⁵ Not compatible to competition.

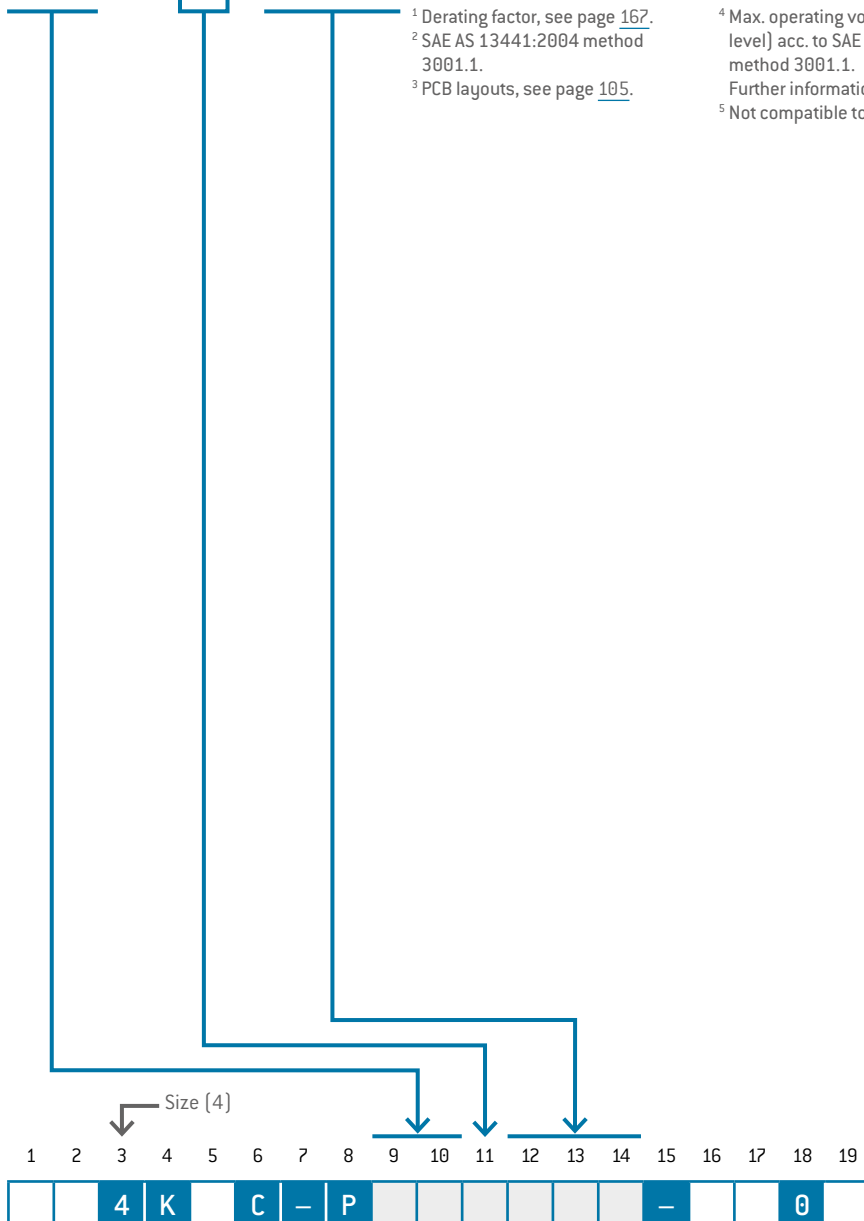

PCB LAYOUTS

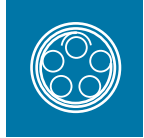

For PCB contacts (Size 4).

	Straight	90° right-angled
7 contacts	<p>Contact borehole: $\varnothing 0.8$ mm</p>	
30 contacts	<p>Contact borehole: $\varnothing 0.6$ mm</p>	<p>Contact borehole: $\varnothing 0.7$ mm</p>
40 contacts	<p>Contact borehole: $\varnothing 0.6$ mm</p>	<p>Contact borehole: $\varnothing 0.7$ mm</p>

All specifications are only valid for socket inserts.
 Pin inserts on request. Further PCB layouts upon request.

RIGHT-ANGLED PCB CONTACTS IN THE RECEPTACLE



A

RIGHT-ANGLED PCB CONTACT
for style G3 and G8



TECHNICAL DATA

- Pin version on request.
- PCB layouts, see page [91](#).

Contact diameter	Termination diameter
0.5	0.5
0.7	0.6
0.9	0.6
1.3	0.8
1.6	0.8
2	0.8

1 2 3 4 5 6 7 8 9 10 11 12 13 14 15 16 17 18 19

			K		C	-	P					0	0	-		0	0	0
--	--	--	---	--	---	---	---	--	--	--	--	---	---	---	--	---	---	---

FOR YOUR NOTES

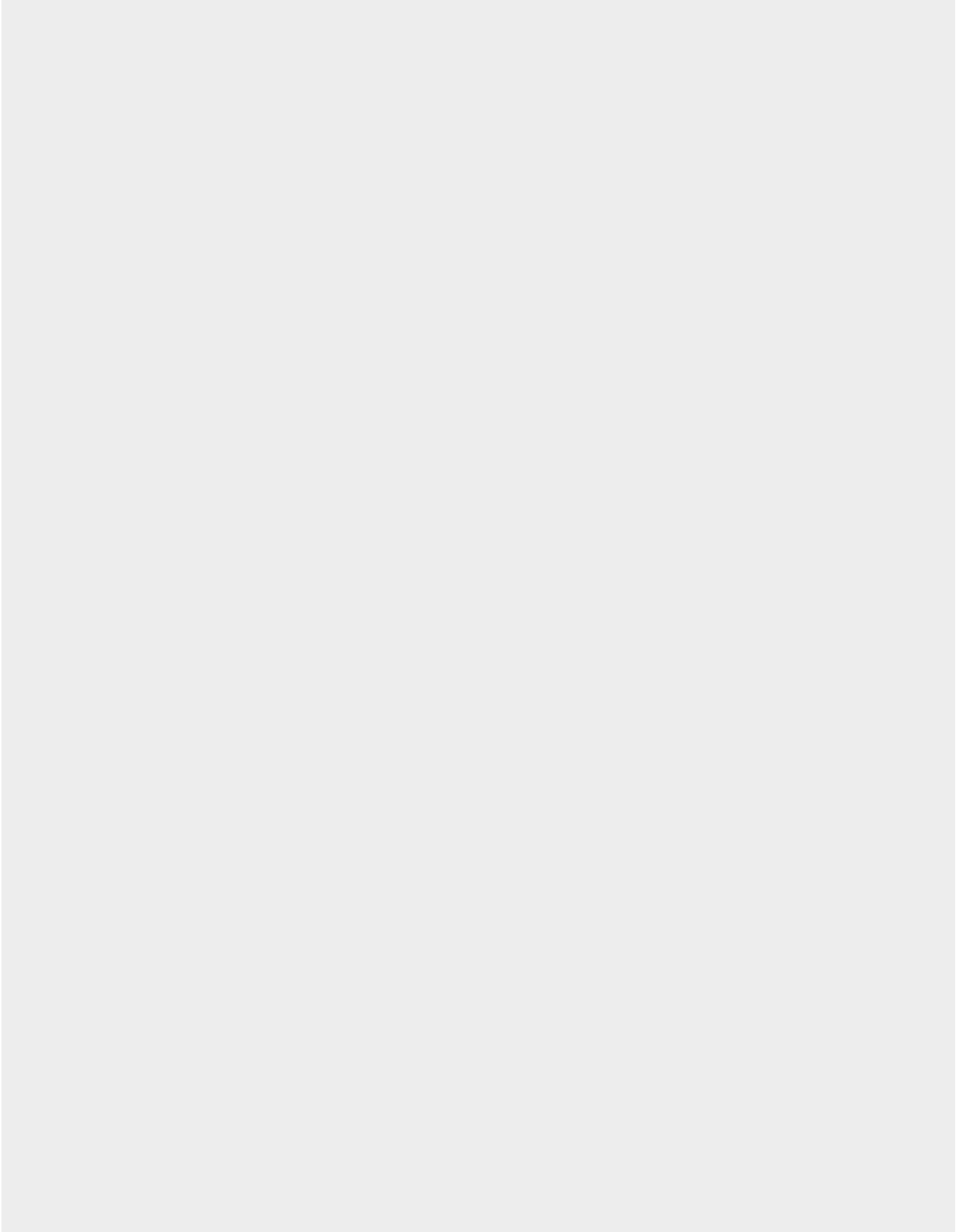

CABLE COLLET SYSTEM



		Cable diameter mm	Size				
			0	1	2	3	4
1	5	> 1 – 1.5		•			
2	0	> 1.5 – 2	•	•			
2	5	> 2 – 2.5	•	•			
3	0	> 2.5 – 3	•	•	•		
3	5	> 3 – 3.5	•	•	•	•	
4	0	> 3.5 – 4	•	•	•	•	
4	5	> 4 – 4.5	•	•	•	•	
5	0	> 4.5 – 5	•	•	•	•	
5	5	> 5 – 5.5		•	•	•	
6	0	> 5.5 – 6		•	•	•	
6	5	> 6 – 6.5		•	•	•	
7	0	> 6.5 – 7		•	•	•	
7	5	> 7 – 7.5			•	•	•
8	0	> 7.5 – 8			•	•	
8	5	> 8 – 8.5			•	•	•
9	0	> 8.5 – 9			•	•	
9	5	> 9 – 9.5				•	•
0	1	> 9.5 – 10				•	
0	2	> 10 – 10.5				•	•
0	3	> 10.5 – 11.5					•
1	4	> 13.5 – 14					•
0	0	Without cable collet system (on request)					

APPLICATION: For all plugs and in-line receptacles and for receptacle style 6 and 7.

USE: Cable collet for strain relief; sealing ring for cable seal; EMI ring for transmission of the shielding.

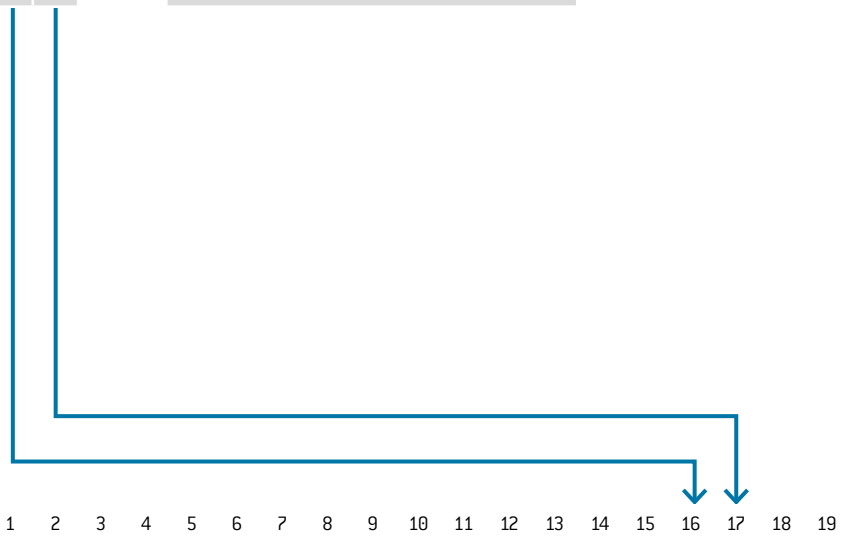
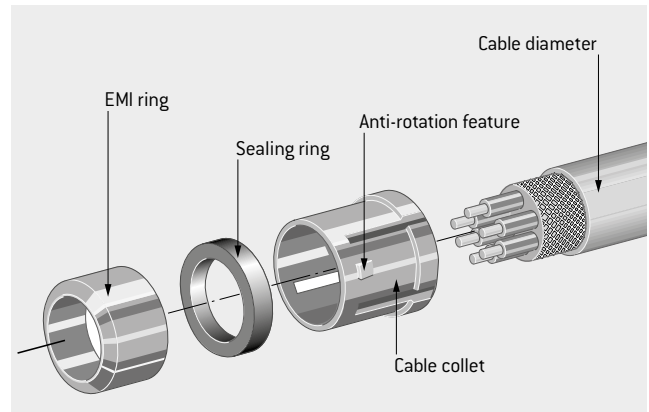

1	2	3	4	5	6	7	8	9	10	11	12	13	14	15	16	17	18	19
				K		C	-	P									0	

For assembly instructions please refer to our website: www.odu-connectors.com/downloads/assembly-instructions

DEFINITION OF THE BACK NUTS



Usable for all straight, right-angled and Break-Away connectors, in-line receptacles, receptacles style 6.

0

STANDARD BACK NUT



S

BACK NUT FOR SILICONE CABLE BEND RELIEF¹



¹ Please order silicone cable bend reliefs separately, see page [111](#).

1	2	3	4	5	6	7	8	9	10	11	12	13	14	15	16	17	18	19	
			K		C	-	P							-				0	

PROTECTIVE COVERS



FOR RECEPTACLE TYPES

Size	Part number	A	Ø B	C	Ø D
		mm	mm	mm	mm
0	720.097.007.215._00	8	15	70	6
1	721.097.007.215._00	9	18.5	75	8
2	722.097.007.215._00	9	21.5	85	10
3	723.097.007.215._00	9.6	24	120	12
4	724.097.007.215._00	11.2	31.5	140	16

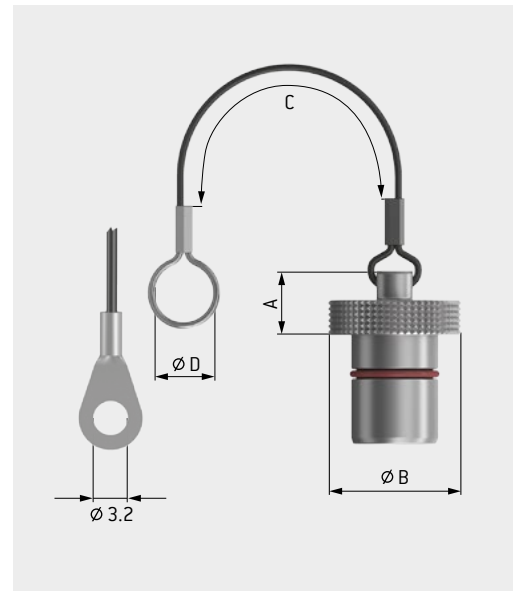

Lanyard material	
0	Polyamide lanyard with loop
1	Stainless steel lanyard with loop
2	Polyamide lanyard with solder lug
3	Stainless steel lanyard with solder lug

Surface matt chromate

FOR PLUG (IP68)

Size	Part number	A	Ø B	C	Ø D
		mm	mm	mm	mm
0	720.097.004.215._0_	16	14	70	6
1	721.097.004.215._0_	21	16	75	8
2	722.097.004.215._0_	21.5	20	85	10
3	723.097.004.215._0_	25.5	24	130	12
4	724.097.004.215._0_	28	30	140	16

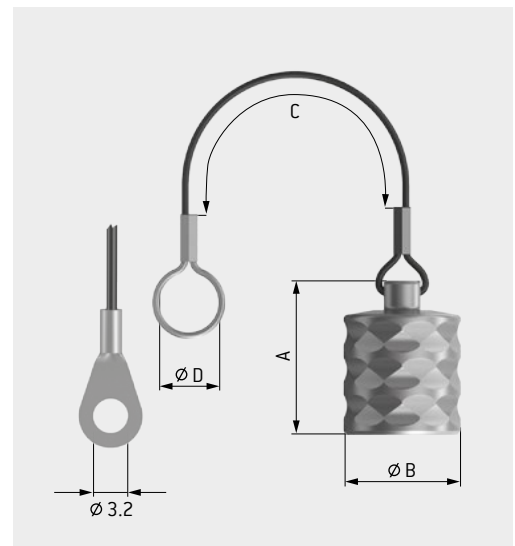

Lanyard material	
0	Polyamide lanyard with loop
1	Stainless steel lanyard with loop
2	Polyamide lanyard with solder lug
3	Stainless steel lanyard with solder lug

Surface matt chromate

Size	Keyings (see page 88)							
	Ø	A	C	F	H	K	Q	W
0	•	•	•	•	o	o	o	o
1	•	•	•	•	o	o	o	o
2	•	•	•	•	o	o	o	o
3	•	•	o	o	o	o	o	o
4	•	o	o	o	o	o	o	o

• Standard, o On request.

SILICONE CABLE BEND RELIEFS



Size	Part number	Dim. L mm	Cable jacket (∅ outside)	
			min.	max.
0	700.023.____.965.020	27	2	2.5
	700.023.____.965.025		2.5	3
	700.023.____.965.030		3	3.5
	700.023.____.965.035		3.5	4
	700.023.____.965.040		4	4.5
	700.023.____.965.045		4.5	5
1	701.023.____.965.025	30	2.5	3
	701.023.____.965.030		3	3.5
	701.023.____.965.035		3.5	4
	701.023.____.965.040		4	5
	701.023.____.965.050		5	6
	701.023.____.965.060		6	6.5
2	702.023.____.965.025	36	2.5	3
	702.023.____.965.030		3	3.5
	702.023.____.965.035		3.5	4
	702.023.____.965.040		4	5
	702.023.____.965.050		5	6
	702.023.____.965.060		6	7
	702.023.____.965.070		7	8
	702.023.____.965.080		8	9
3	703.023.____.965.040	42	4	5
	703.023.____.965.050		5	6
	703.023.____.965.060		6	7
	703.023.____.965.070		7	8
	703.023.____.965.080		8	9
	703.023.____.965.090		9	10
	703.023.____.965.100		10	11
	703.023.____.965.110		11	12
4	704.023.____.965.080	60	8	10
	704.023.____.965.100		10	12
	704.023.____.965.120		12	14
	704.023.____.965.140		14	16

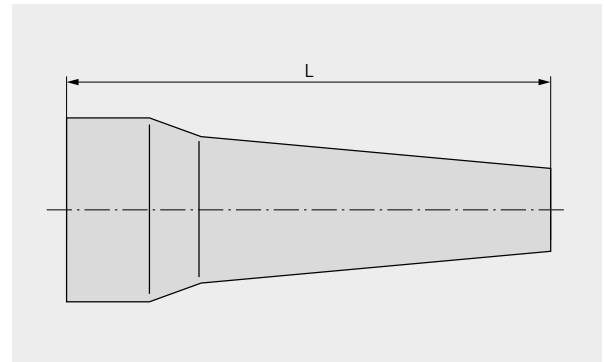

TEMPERATURE RANGE

Silicone: -50 °C up to +200 °C, short-term up to +230 °C
Autoclaveable

COLORS

Color code	Color	RAL no. ¹ (similar)
202	Red	3020
203	White	9010
204	Yellow	1016
205	Green	6029
206	Blue	5002
207	Gray	7005
208	Black	9005



¹ Because of different raw materials, the colors may slightly differ from RAL numbers.

BACK NUT FOR CABLE BEND RELIEFS



EXAMPLE OF ASSEMBLY

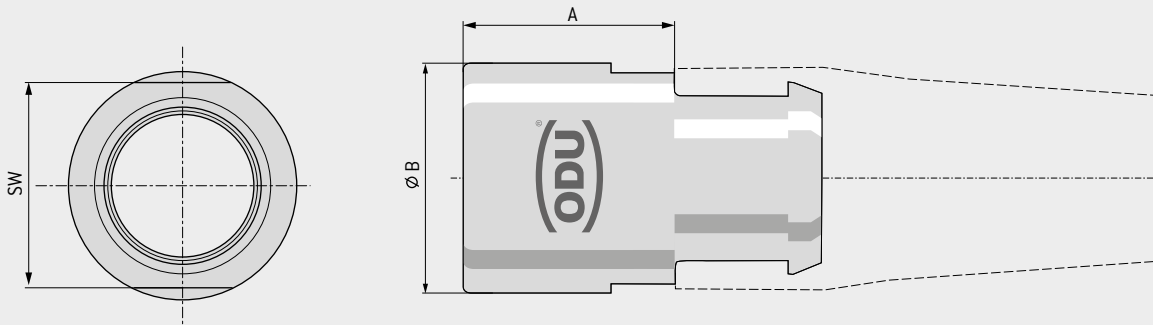

Size	Part number	A	Ø B	SW
		mm	mm	mm
0	700.022.1173__002	8	8.9	7
1	701.022.1173__002	10	10.9	10
2	702.022.1173__002	11.5	13.9	13
3	753.022.1173__002	11.5	16.9	15
4	704.022.1173__002	15	23	20

Surface	
15	Cu-alloy / matt chrome plated
61	Cu-alloy / tin-nickel plated
04	Cu-alloy / nickel





TOOLS

The following pages contain tools and wrenches to ensure that your ODU connectors function flawlessly.

CRIMPING TOOLS / ASSEMBLY TOOLS



PART NUMBER CRIMPING TOOL
080.000.051.000.000

Part number positioner,
see table.

PROCESSING TOOL FOR CRIMP CONTACTS

Digital adjustment, multiposition

Size	Number of contacts	Contact diameter mm	Termination cross-section		Adjustment dim. mm	Positioner	Positioning setting		Removal tool
			AWG	mm ²			Pin	Socket	
0	4-5	0.7	28-32	0.09-0.04	0.57	080.000.051.105.000	1	2	087.7CC.070.001.000
	4-5	0.7	22-26	0.38-0.15	0.67	080.000.051.105.000	1	2	087.7CC.070.001.000
	2-3	0.9	22-26	0.38-0.15	0.67	080.000.051.105.000	3	4	087.7CC.090.001.000
	2-3	0.9	20-24	0.5-0.25	0.67	080.000.051.105.000	3	4	087.7CC.090.001.000
1	6-8	0.7	28-32	0.09-0.04	0.57	080.000.051.105.000	1	5	087.7CC.070.001.000
	6-8	0.7	22-26	0.38-0.15	0.67	080.000.051.105.000	1	5	087.7CC.070.001.000
	4-5	0.9	22-26	0.38-0.15	0.67	080.000.051.105.000	3	6	087.7CC.090.001.000
	4-5	0.9	20-24	0.5-0.25	0.67	080.000.051.105.000	3	6	087.7CC.090.001.000
	2-3	1.3	18-20	1-0.5	1.12	080.000.051.105.000	7	8	087.7CC.130.001.000
2	12-19	0.7	28-32	0.09-0.04	0.57	080.000.051.106.000	1	2	087.7CC.070.001.000
	12-19	0.7	22-26	0.38-0.15	0.67	080.000.051.106.000	1	2	087.7CC.070.001.000
	8-10	0.9	22-26	0.38-0.15	0.67	080.000.051.106.000	3	4	087.7CC.090.001.000
	8-10	0.9	20-24	0.5-0.25	0.67	080.000.051.106.000	3	4	087.7CC.090.001.000
	4-7	1.3	20-24	0.5-0.25	0.67	080.000.051.106.000	5	6	087.7CC.130.001.000
	4-7	1.3	18-20	1-0.5	1.12	080.000.051.106.000	5	6	087.7CC.130.001.000
	3	1.6	18-20	1-0.5	1.12	080.000.051.107.000	1	2	087.7CC.160.001.000
	3	1.6	18	1.5-1	1.12	080.000.051.107.000	1	2	087.7CC.160.001.000
	3	1.6	14-16	1.5-1	1.3	080.000.051.107.000	1	2	087.7CC.160.001.000
	2	2	18	1.5-1	1.12	080.000.051.107.000	3	4	087.7CC.200.002.000
2	2	14-16	1.5-1	1.3	080.000.051.107.000	3	4	087.7CC.200.002.000	
3	20-30	0.7	28-32	0.09-0.04	0.57	080.000.051.106.000	1	7	087.7CC.070.001.000
	20-30	0.7	22-26	0.38-0.15	0.67	080.000.051.106.000	1	7	087.7CC.070.001.000
	14-18	0.9	22-26	0.38-0.15	0.67	080.000.051.106.000	3	8	087.7CC.090.001.000
	14-18	0.9	20-24	0.5-0.25	0.67	080.000.051.106.000	3	8	087.7CC.090.001.000
	8-10	1.3	20-24	0.5-0.25	0.67	080.000.051.106.000	5	9	087.7CC.130.001.000
	8-10	1.3	18-20	1-0.5	1.12	080.000.051.106.000	5	9	087.7CC.130.001.000
	7	1.6	18-20	1-0.5	1.12	080.000.051.107.000	1	5	087.7CC.160.001.000
	7	1.6	18	1.5-1	1.12	080.000.051.107.000	1	5	087.7CC.160.001.000
	7	1.6	14-16	1.5-1	1.3	080.000.051.107.000	1	5	087.7CC.160.001.000

CRIMPING TOOLS / ASSEMBLY TOOLS



PART NUMBER CRIMPING TOOL
080.000.037.000.000

Part number positioner,
see table.

PROCESSING TOOL FOR CRIMP CONTACTS

Mil approved, single position

Size	Number of contacts	Contact diameter mm	Termination cross-section		Positioner		Selector setting		Removal tool
			AWG	mm ²	Pin	Socket	Pin	Socket	
0	4-5	0.7	28-32	0.09-0.04	081.701.002.848.037		3		087.7CC.070.001.000
	4-5	0.7	22-26	0.38-0.15	081.701.002.848.037		4		087.7CC.070.001.000
	2-3	0.9	22-26	0.38-0.15	081.701.002.849.037	081.700.004.749.037	4	4	087.7CC.090.001.000
	2-3	0.9	20-24	0.5-0.25	081.701.003.849.037	081.700.003.749.037	7/6/5 ¹	7/6/5 ¹	087.7CC.090.001.000
1	6-8	0.7	28-32	0.09-0.04	081.701.002.848.037	081.701.002.748.037	3	3	087.7CC.070.001.000
	6-8	0.7	22-26	0.38-0.15	081.701.002.848.037	081.701.002.748.037	4	4	087.7CC.070.001.000
	4-5	0.9	22-26	0.38-0.15	081.701.002.849.037	081.701.002.749.037	4	4	087.7CC.090.001.000
	4-5	0.9	20-24	0.5-0.25	081.701.003.849.037	081.701.003.749.037	7/6/5 ¹	7/6/5 ¹	087.7CC.090.001.000
2	12-19	0.7	28-32	0.09-0.04	081.702.001.848.037	081.702.001.748.037	3	3	087.7CC.070.001.000
	12-19	0.7	22-26	0.38-0.15	081.702.001.848.037	081.702.001.748.037	4	4	087.7CC.070.001.000
	8-10	0.9	22-26	0.38-0.15	081.701.002.849.037	081.702.003.749.037	4	4	087.7CC.090.001.000
	8-10	0.9	20-24	0.5-0.25	081.701.003.849.037	081.702.002.749.037	7/6/5 ¹	7/6/5 ¹	087.7CC.090.001.000
3	20-30	0.7	28-32	0.09-0.04	081.702.001.848.037	081.703.002.748.037	3	3	087.7CC.070.001.000
	20-30	0.7	22-26	0.38-0.15	081.702.001.848.037	081.703.002.748.037	4	4	087.7CC.070.001.000
	14-18	0.9	22-26	0.38-0.15	081.701.002.849.037		4		087.7CC.090.001.000
	14-18	0.9	20-24	0.5-0.25	081.701.003.849.037		7/6/5 ¹		087.7CC.090.001.000
	8	1.3	20-24	0.5-0.25	081.703.001.844.037	081.703.001.744.037	7/6/5 ¹	7/6/5 ¹	087.7CC.130.001.000
	8	1.3	18-20	1-0.5		081.703.001.744.037		5	087.7CC.130.001.000

¹ For AWG 20 position 7 / for AWG 22 position 6 / for AWG 24 position 5.

SPANNER WRENCH

Part number	Dimensions in mm				
	SW	t	B	L	b
598.700.001.016.000	5	1.5	16	92	8
598.700.001.015.000	5.5	1.5	16	92	8
598.700.001.021.000	6	2	16	92	8
598.700.001.011.000	7	2	16	92	8
598.700.001.001.000	8	2	16	92	8
598.700.001.022.000	9	2	21.5	102	9
598.700.001.002.000	10	2	21.5	102	9
598.700.001.012.000	11	2	24.5	115	10
598.700.001.003.000	12	2.5	24.5	115	10
598.700.001.017.000	12.5	4	24.5	115	10
598.700.001.004.000	13	2.5	30.5	98	16.5
598.700.001.005.000	14	2.5	30.5	98	16.5
598.700.001.006.000	15	3	35.5	145	15
598.700.001.007.000	16	3	35.5	145	15
598.700.001.008.000	17	3	35.5	145	15
598.700.001.023.000	18	3	42	172	16
598.700.001.013.000	19	3	42	172	16
598.700.001.009.000	20	3	42	172	16
598.700.001.018.000	21	3	42	172	16
598.700.001.010.000	22	3	47	119	23.5
598.700.001.014.000	24	3	54	119	23.5
598.700.001.024.000	27	3	55	150	25
598.700.001.019.000	30	3	50	150	25
598.700.001.020.000	31	3	50	150	25

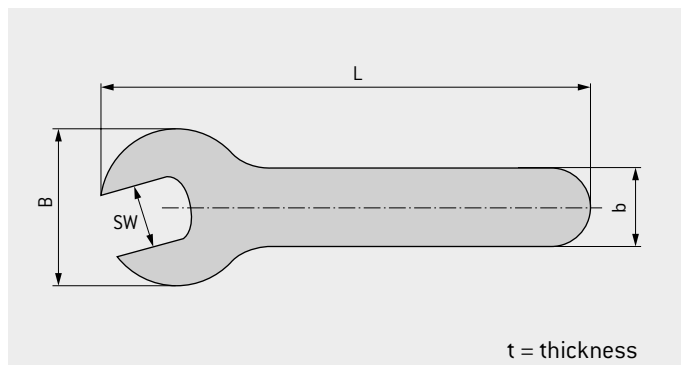

NUTDRIVER FOR SLOTTED MOUNTING NUT



Nutdriver	Thread	Dimensions in mm
		L

SUITABLE FOR STYLE 8 / SERIES L AND B:

700.098.002.000.000	M 9 × 0.5	50
700.098.001.000.000	M 10 × 0.5	50
700.098.001.000.000	M 12 × 1	50
701.098.002.000.000	M 14 × 1	60
701.098.001.000.000	M 15 × 1	60
702.098.001.000.000	M 16 × 1	60
702.098.001.000.000	M 18 × 1	60
703.098.001.000.000	M 20 × 1	60

SUITABLE FOR STYLE 3 / SERIES K:

701.098.002.000.000	M 14 × 1	60
721.098.001.000.000	M 16 × 1	60
703.098.001.000.000	M 20 × 1	60
724.098.001.000.000	M 30 × 1	60

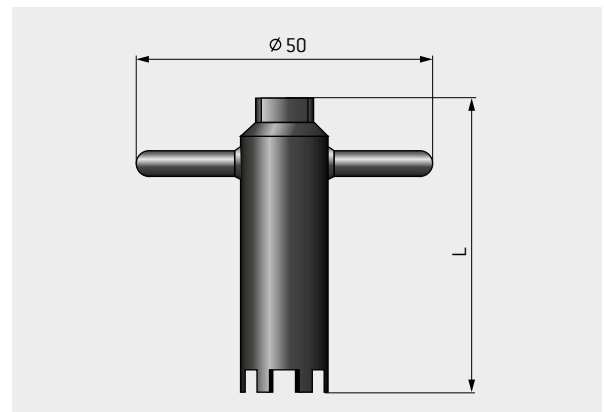

REMOVAL TOOLS FOR CRIMP-CLIP-CONTACTS

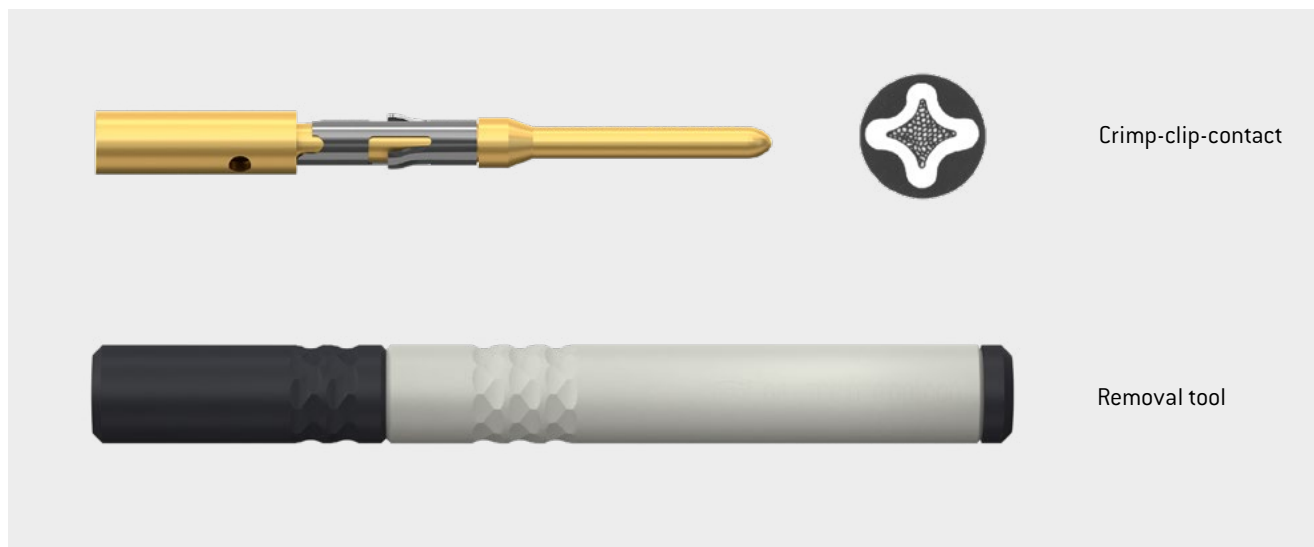

Crimp-clip-contact

Removal tool

Part number	Contact Ø mm
087.7CC.070.001.000	0.7
087.7CC.090.001.000	0.9
087.7CC.130.001.000	1.3
087.7CC.160.001.000	1.6
087.7CC.200.002.000	2

ASSEMBLY TOOL FOR SERIES K

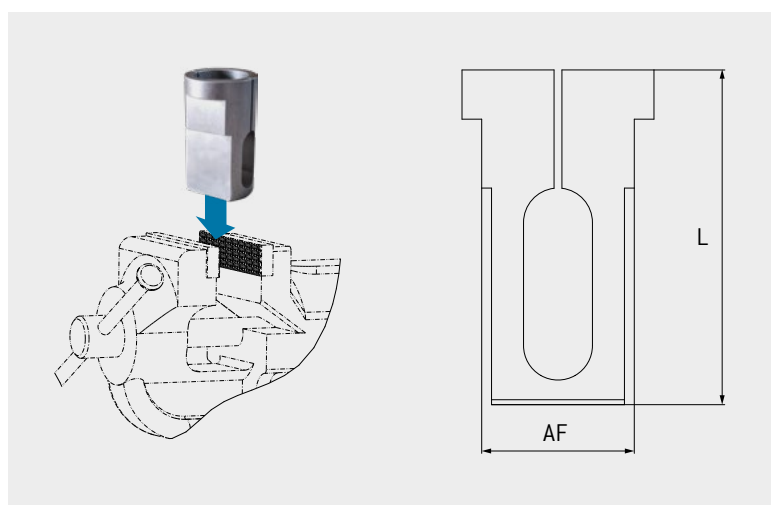

Size	Part number	AF mm	L mm
0	080.000.055.631.100	11.0	25
1	080.000.055.631.101	13.0	28
2	080.000.055.631.102	15.5	34
3	080.000.055.631.103	18.5	36
4	080.000.055.631.104	22.0	40

- To hold the inner housing while mounting the back nut

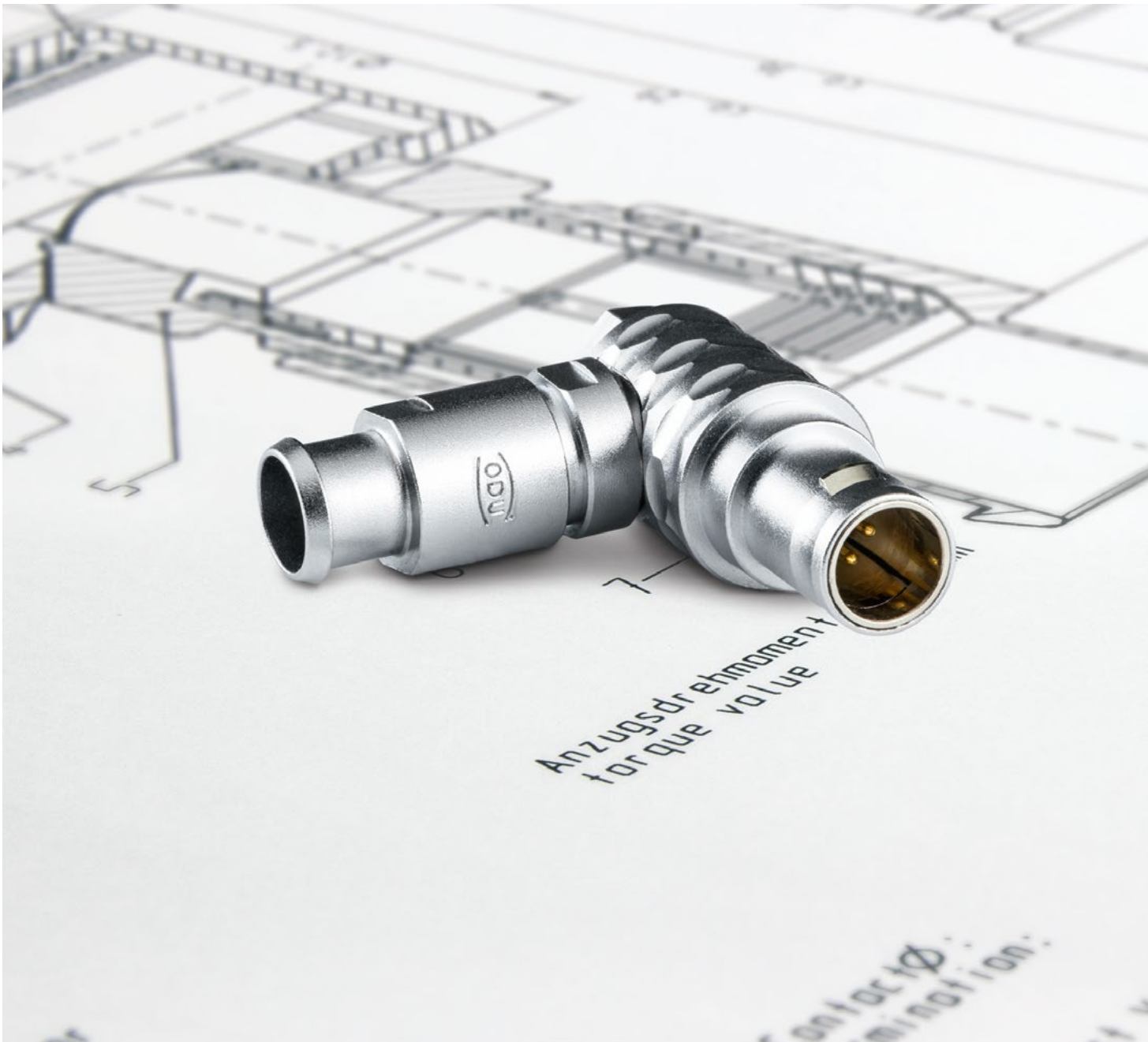

ODU MINI-SNAP®

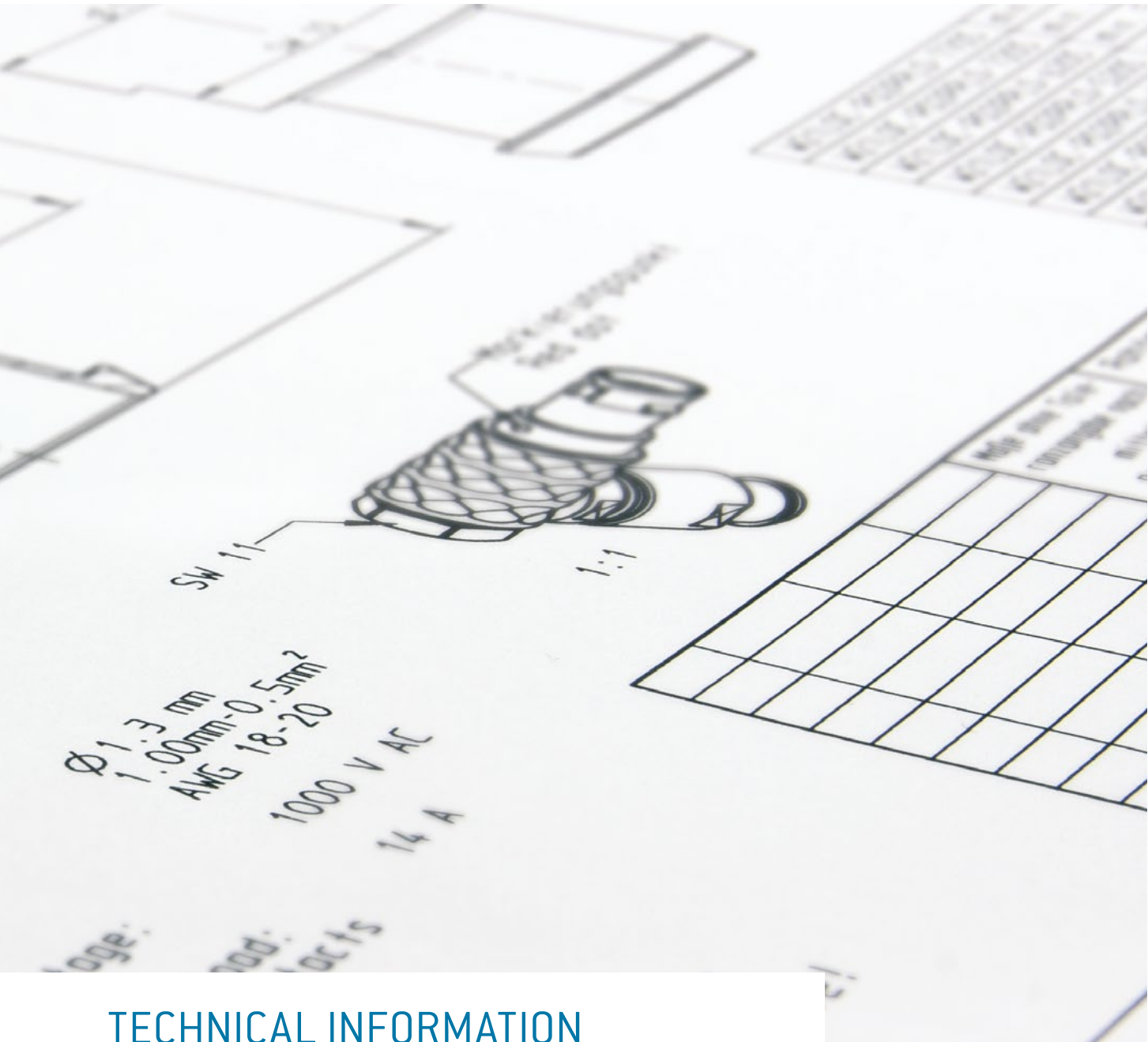

TECHNICAL INFORMATION

ODU connectors ensure perfect and reliable transmission of power, signal, data and other media in a wide variety of applications.

Further information can be found on the following pages.

INTERNATIONAL PROTECTION CLASSES



Acc. IEC 60529:2013 (VDE 0470-1:2014).

Code letters (International Protection)		First code number (Degrees of protection against access to hazardous parts respectively against solid foreign objects)		Second code number (Degrees of protection against water)	
IP		6		5	
Code number	Protection against access to hazardous parts / Protection against ingress of solid foreign objects			Code number	Protection against harmful effects due to the ingress of water
0	No protection		No protection against contact / No protection against solid foreign objects	0	No protection against water
1	Protection against large foreign objects		Protection against contact with the back of the hand / Protection against solid foreign objects $\varnothing \geq 50$ mm	1	Protection against dripping water
2	Protection against medium-sized foreign objects		Protection against contact with the fingers / Protection against solid foreign objects $\varnothing \geq 12.5$ mm	2	Protection against angular dripping water (from angles)
3	Protection against small foreign objects		Protection against contact with tools / Protection against solid foreign objects $\varnothing \geq 2.5$ mm	3	Protection against spray water
4	Protection against granular foreign objects		Protection against contact with a wire / Protection against solid foreign objects $\varnothing \geq 1.0$ mm	4	Protection against splashing water
5	Dustproof		Protection against contact with a wire / Protection against uncontrolled ingress of dust	5	Protection against water jet
6	Dustproof		Protection against contact with a wire / Complete protection against ingress of dust	6	Protection against powerful water jet
				7	Protection against the effects of temporary immersion in water
				8	Protection against the effects of continuous immersion in water
				9	Protection against high pressure water jet featuring high temperatures

PRINCIPLE OF WATERTIGHTNESS WITH ODU MINI-SNAP®



ODU makes both IP50 and IP68 in the L and B series in the same diameter. For reasons of compatibility with the competition, ODU now offers the series K as well, which has a greater diameter than the non-watertight model (series L).

1. CASE:

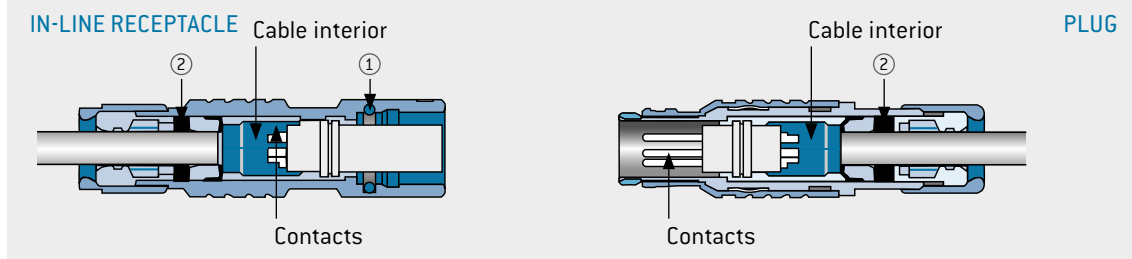

2. CASE:

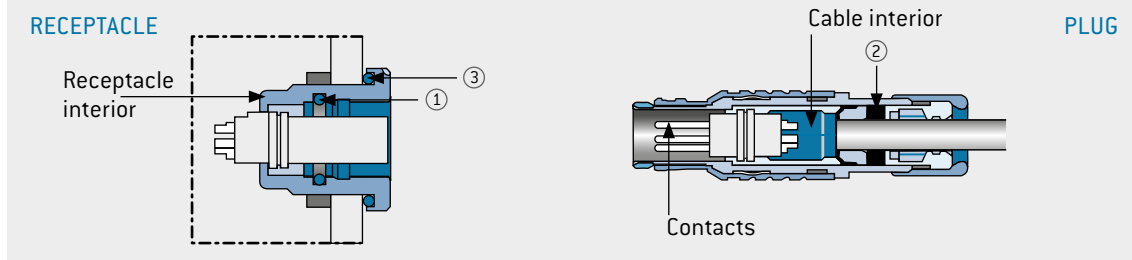

3. CASE:

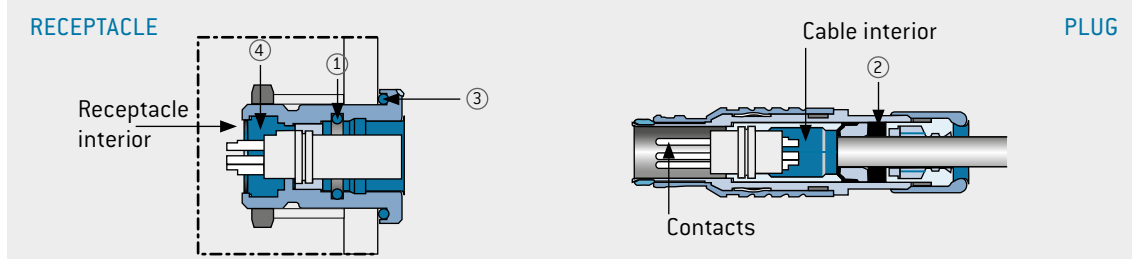

All IP68 submersible ODU MINI-SNAP connectors have a rated water depth of 2 m (0.2 bar) for 24 hours in accordance with IEC 60529:2013 (VDE 0470-1:2014). A watertight connector requires a sealing in a cable collet system. The sleeve must fit over the cable precisely. The cable jacket must be smooth, cylindrical and free of grooves. The connector should be encapsulated to make it watertight when not mated.

PROTECTION AGAINST WATER BY THE FOLLOWING SEALINGS¹

Case	Termination	Mated		Unmated	
		Tight	Position	Tight	Position
1	Cable interior	Yes	①②	No	
2	Receptacle interior	Yes	①②③	No	
3	Receptacle interior	Yes	①②③	Yes	③④

① O-ring ② Elastic sealing² ③ O-ring ④ Grouting

¹ The following applies to the contacts: the contacts are protected in cases 1, 2 and 3 when mated. When not mated, the contacts are only protected by a protective cover [see page 69 for series L, page 110 for series K and page 148 for series B] which must be removed before mating.² The cable seal with elastic disks requires coordination with the cable. Decisive factors: Diameter tolerance, roundness, cable structure, cable jacket hardness.

HOUSING MATERIALS / SURFACES



Component	Material designation	Surface
Connector plug housing Back nut Decorative slotted mounting nut	Cu-alloy	Cr ¹
Cable collet EMI ring Half-shell Lock washer Nut Retainer Ring	Cu-alloy	Ni
Contact pin (solder/PCB) Contact socket (solder/PCB) Contact pin (crimp) Contact socket (crimp)	Cu-alloy	Au

ODU MINI-SNAP connector plug housings are made of brass, nickel plated and then matt chrome plated. Nickel and tin-nickel plated connector plug housings are available upon request as special materials (not autoclavable). The internal parts are made of nickel plated brass.

INSULATOR MATERIALS (COMPLIANT TO ROHS 2011/65/EU)

	Norm	Unit	PEEK
Dielectric strength	IEC 60243-1:2013 (VDE 0303-21:2014)	KV/mm	19
Operation temperature	ASTM D 149:2009	°C	-50/+250
Flammability rating	UL-94:2013	-	V-0
Comparative tracking index CTI	IEC 60112:2009 (VDE 0303-11:2010)		175

¹ Tin-nickel plated on request. Choice in the part number key, see page 39 (series L), page 88 (series K), page 125 (series B).

TERMINATION TECHNOLOGIES



Insulators with pin contacts fit into the receptacle (or in-line receptacle) as well as into the plug. The same applies to insulators with socket contacts. In general, insulators with socket contacts are installed in the live part (to provide protection from accidental touch).

The means of mounting the contacts in the insulator is important on account of the termination technologies. Termination technologies for ODU MINI-SNAP connectors include: soldering, crimping and PCB.

SOLDER TERMINATION



CRIMP-CLIP-CONTACT FOR PEEK INSULATOR



PRINT TERMINATION



TERMINATION TECHNOLOGIES FOR TURNED CONTACTS

Solder termination

The contacts are mounted in the insulator before the single connectors are assembled.

An insulator with pre-installed contacts is referred to as a contact insert.

Crimp termination

Here, the individual contact is connected to the individual wires via deformation in the termination area. Then the contacts are individually installed in the insulator. Accordingly, insulators and individual contacts – and not complete contact inserts – are supplied for the crimp termination. The contact processing for the production of connecting cables via crimping creates a secure, durable and corrosion-free contact. Cold compaction (crimping) compresses the conductor and contact material to the press points so as to form a gas-tight connection with tensile strength to fit the conductor material. 8-point deformation is generally used for turned crimp contacts.

PCB termination

This is only used in the receptacle if the receptacle is to be mounted directly on a printed circuit board (PCB). Further information is available upon request.

CONVERSIONS/AWG (AMERICAN WIRE GAUGE)



Circular wire					
AWG	Diameter		Cross-section mm ²	Weight kg / km	Max. resistance Ω / km
	Inch	mm			
10 (1)	0.1019	2.590	5.26	46.77	3.45
10 (37/26)	0.1150	2.921	4.74	42.10	4.13
12 (1)	0.0808	2.050	3.31	29.41	5.45
12 (19/25)	0.0930	2.362	3.08	27.36	6.14
12 (37/28)	0.0910	2.311	2.97	26.45	6.36
14 (1)	0.0641	1.630	2.08	18.51	8.79
14 (19/27)	0.0730	1.854	1.94	17.23	9.94
14 (37/30)	0.0735	1.867	2.08	18.870	10.50
16 (1)	0.0508	1.290	1.31	11.625	13.94
16 (19/29)	0.0590	1.499	1.23	10.928	15.70
18 (1)	0.0403	1.020	0.823	7.316	22.18
18 (19/30)	0.0052	1.321	0.963	8.564	20.40
20 (1)	0.0320	0.813	0.519	4.613	35.10
20 (7/28)	0.0390	0.991	0.563	5.003	34.10
20 (19/32)	0.0420	1.067	0.616	5.473	32.00
22 (1)	0.0253	0.643	0.324	2.883	57.70
22 (7/30)	0.0288	0.732	0.324	2.965	54.80
22 (19/34)	0.0330	0.838	0.382	3.395	51.80
24 (1)	0.0201	0.511	0.205	1.820	91.20
24 (7/32)	0.0250	0.635	0.227	2.016	86.00
24 (19/36)	0.0270	0.686	0.241	2.145	83.30
26 (1)	0.0159	0.404	0.128	1.139	147.00
26 (7/34)	0.0200	0.508	0.141	1.251	140.00
26 (19/38)	0.0220	0.559	0.154	1.370	131.00
28 (1)	0.0126	0.320	0.0804	0.715	231.00
28 (7/36)	0.0160	0.406	0.0889	0.790	224.00
28 (19/40)	0.0170	0.432	0.0925	0.823	207.00
30 (1)	0.0100	0.254	0.0507	0.450	374.00
30 (7/38)	0.0130	0.330	0.0568	0.505	354.00
30 (19/42)	0.0123	0.312	0.0720	0.622	310.00
32 (1)	0.0080	0.203	0.0324	0.288	561.00
32 (7/40)	0.0110	0.279	0.0341	0.303	597.10
32 (19/44)	0.0100	0.254	0.0440	0.356	492.00
34 (1)	0.0063	0.160	0.0201	0.179	951.00
34 (7/42)	0.0070	0.180	0.0222	0.197	1,491.00
36 (1)	0.0050	0.127	0.0127	0.1126	1,519.00
36 (7/44)	0.0060	0.150	0.0142	0.1263	1,322.00

The American Wire Gauge (AWG) is based on the principle that the cross-section of the wire changes by 26% from one gauge number to the next. The AWG numbers decrease as the wire diameter increases, while the AWG numbers increase as the wire diameter decreases. This only applies to solid wire.

However, stranded wire is predominately used in practice. This has the advantage of a longer service life under bending and vibration as well as greater flexibility in comparison with solid wire.

Stranded wires are made of multiple, smaller-gauge wires (higher AWG number). The stranded wire then receives the AWG numbers of a solid wire with the next closest cross-section to that of the stranded wire. In this case, the cross-section of the stranded wire refers to the sum of the copper cross-sections of the individual wires.

Accordingly, strands with the same AWG number but different numbers of wires differ in cross-section. For instance, an AWG 20 strand of 7 AWG 28 wires has a cross-section of 0.563 mm², while an AWG 20 strand of 19 AWG 32 wires has a cross-section of 0.616 mm².

Source: ASTM

CURRENT LOAD OF TURNED CONTACTS



Nominal single contact current load for pin / slotted socket (nominal diameter 0.5 mm – 2.0 mm)

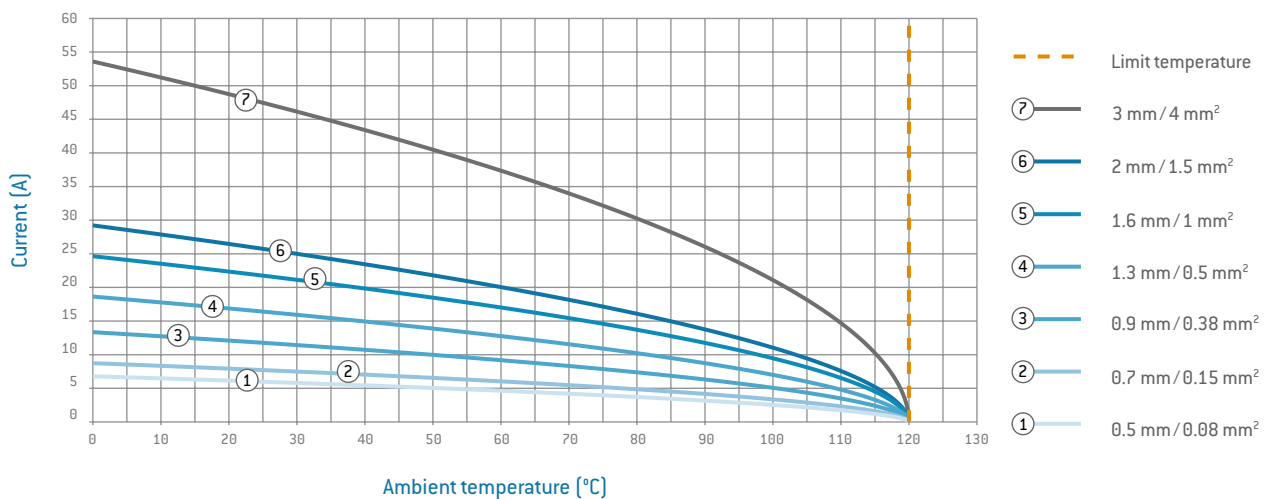
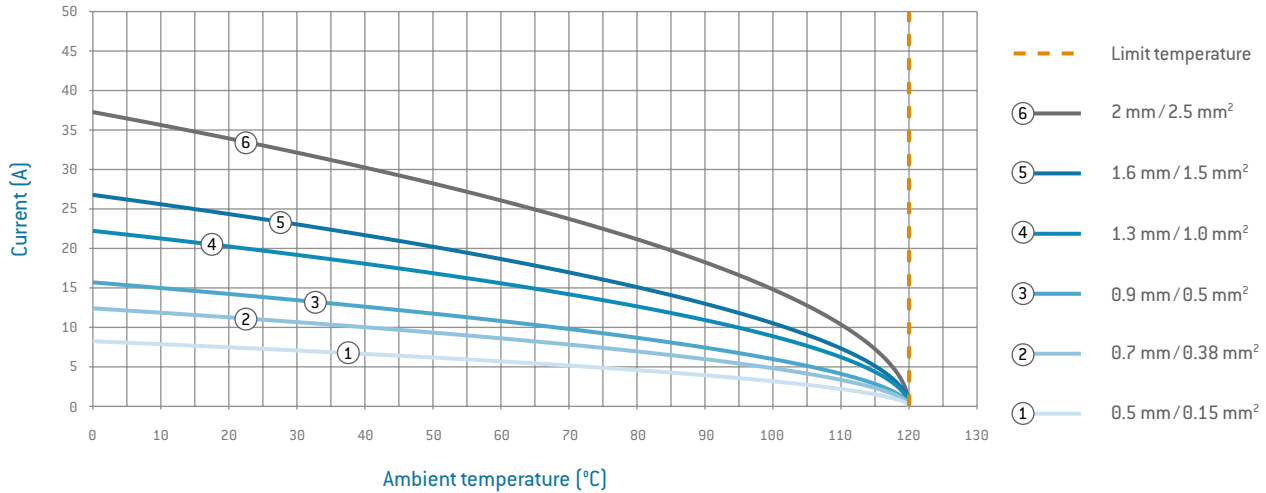

UPPER LIMIT TEMPERATURE OF STANDARD CONTACTS: +120 °C

The wire cross-section shown in the legend was connected as test cable. In the case of multi-position connectors and cables, the heating is greater than it is with individual contacts. For that reason, it is calculated with a reduction factor.

For connectors, the reduction factors for multi-core cables pursuant to VDE 0298-4:2013 are applied. The reduction factor is factored in at 5 live wires and up.

DERATING CURVE

The corrected current-carrying capacity curve, derived from the base curve determined (0.8 x measured current). It factors in manufacturing tolerances as well as uncertainties in temperature measurement and measurement arrangement. See derating measurement method.

RATED CURRENT (NOMINAL CURRENT)

The metrologically determined current which is permitted to flow continuously through all contacts at the same time and will increase the contact temperature by 45 Kelvin.

The amperage is determined according to the derating measurement method (IEC 60512-5-2:2002 (DIN EN 60512-5-2:2003) and derived from the derating curve.

DERATING FACTOR

Number of loaded wires	Derating factor
5	0.75
7	0.65
10	0.55
14	0.5
19	0.45
24	0.4

OPERATING VOLTAGE



Acc. SAE AS 13441:2004 method 3001.1

The values specified in the catalog correspond to SAE AS 13441:2004 method 3001.1. The table values were determined according to EIA 364-20E:2015. The inserts were tested while mated, and the test current was applied to the pin insert.

75 % of the dielectric withstanding voltage is used for the further calculation. The operating voltage is 1/3 of this value.

All tests were conducted at normal indoor climate and apply up to an altitude of 2,000 m. If there are any deviations, the reduction factors are to be factored in according to the applicable standards. Test voltage:
Dielectric withstanding voltage $\times 0.75$ Operating voltage: Dielectric withstanding voltage $\times 0.75 \times 0.33$

ATTENTION:

With certain applications, the safety requirements for electrical devices are very strict in terms of operating voltage. In such cases, the operating voltage is defined according to the clearance and creepage distances between parts which could be touched.

When selecting such a connector, please contact us and let us know the safety standard which the product must meet.

Test voltage: Dielectric withstanding voltage $\times 0.75$

Operating voltage: Dielectric withstanding voltage $\times 0.75 \times 0.33$

ELECTRO MAGNETIC COMPATIBILITY (EMC)

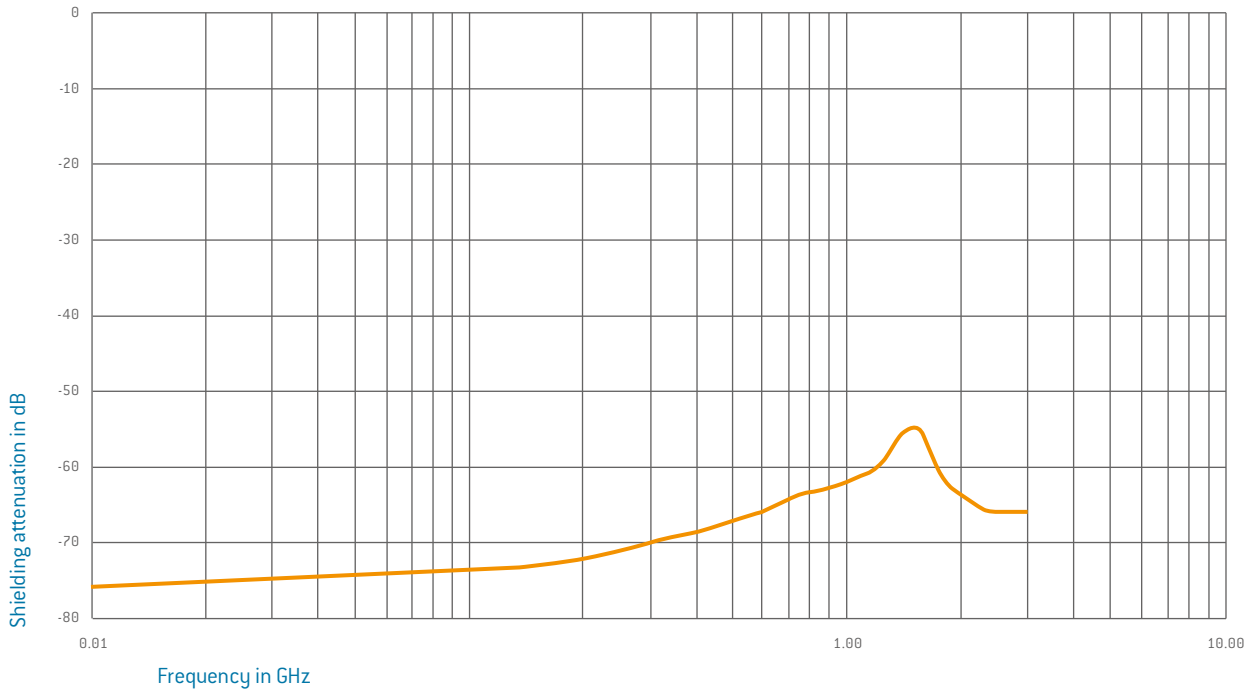

Electromagnetic compatibility (EMC) concerns more than just devices and electronic circuits. In the age of networks and data communication, connecting elements such as cables and connectors are also very important. Interference signals penetrating the connector from outside corrupt data signals and can cause significant system malfunctions. This can be reliably avoided with high-grade shielding for the cables and connectors. In order to give our customers certainty when using ODU MINI-SNAP connectors, we've had a size 3 connector measured by an accredited EMC laboratory to determine its EMC quality. Since the sizes 0, 1 and 2 are identical to this connector in structure, just proportionally reduced in size, the values for shielding attenuation are the same.

The measurement was conducted according to the injection or parallel wire method pursuant to VG 95214-11:2002. The connector pair is connected to the receiver of a network analyzer on one end, while the other end receives an adjusted termination resistor. The injection wire is attached as closely as possible along the connector pair. A flat cable is usually used here, since an optimum adjustment can be achieved by attaching more or fewer wires. High-frequency signals in the 10 kHz to 3 GHz range are now fed in through the injection wire. The network analyzer measures the energy irradiated through the connector plug housing and into the connector, providing a shielding attenuation factor as the logarithmic performance ratio AT in dB. The important thing with this method is that all supply lines (especially the ones to the connector pair) must be very well shielded so that no interference signals can penetrate the measurement system and corrupt the measured values. This provides the shielding attenuation in dB as a curve over the logarithmically applied frequency.

Users frequently demand a shielding attenuation better than -55 dB (based on a requirement of Deutsche Post). It is clear that our connector meets this requirement over the entire measurement range.

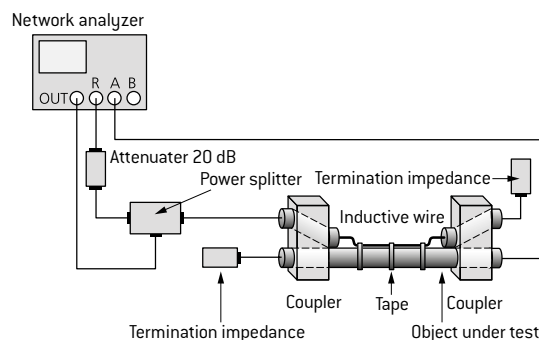

AUTOCLAVING OF ODU MINI-SNAP®



We can also provide ODU MINI-SNAP connectors for the following sterilization procedures upon request: steam sterilization via pre-vacuum or gravity method. The connectors are tested in autoclaves for 500 cycles at 134 °C in accordance with DIN EN 13060:2015.

Please consult our technical team for the further sterilization procedure.

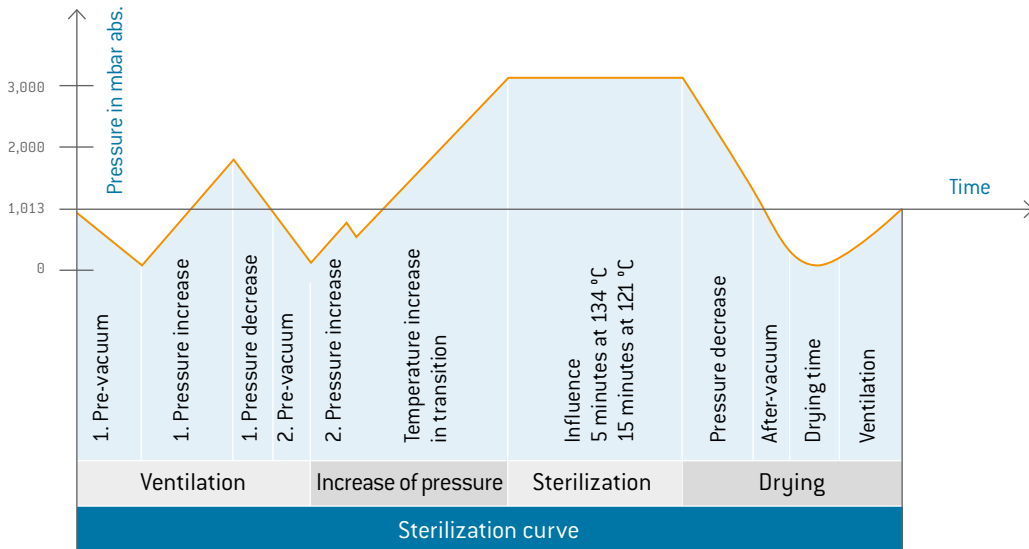

TECHNICAL TERMS



AMBIENT TEMPERATURE

Temperature of the air or other medium in which a piece of equipment is intended to be used. (IEC 44/709/CDV:2014 (VDE 0113-1:2014)).

AUTOCLAVABILITY

See page [170](#).

AWG

American Wire Gauge – see page [166](#).

BASE CURVE

A current-carrying capacity curve metrologically determined according to the method described in IEC 60512-5-2:2002 (DIN EN 60512-5-2:2003) depending on the permissible limit temperature of the materials.

CHEMICAL RESISTANCE

Many secondary processing procedures use adhesives, cleaning agents or other chemicals on our products. Contact with unsuitable chemicals may have an adverse effect on the mechanical and electrical properties of the insulation and housing materials which specified properties may not be able to withstand. Please observe our processing suggestions and technical instructions in this catalog.

CLEARANCE DISTANCE

The shortest distance in the air between two conductive parts.

CONNECTORS

Also known as connectors without contact rating (COC): (IEC 61984:2008 (VDE 0627:2009)). An element which enables electrical conductors to be connected and is intended to create and/or separate connections with a suitable counterpart.

CONNECTOR WITHOUT BREAKING CAPACITY (COC)

Connector which is not deemed to be engaged or disengaged in normal use when live under load.

CONTACT RESISTANCE

Total resistance value measured from terminal to terminal. In this case, the resistance is significantly lower than the contact resistance. The specifications are average values.

CORES

Electrical conductor, solid wire or multi-wire strand, with insulation as well as any conductive layers. Cables or leads may have one or more cores.

CREEPAGE DISTANCES

The shortest distance between two conductive parts along the surface of a solid insulation material. This factors in all elevations and recesses in the insulator, as long as defined minimum dimensions are on hand.

CRIMP BARREL

A terminal sleeve which can accommodate one or more conductors and be crimped by a crimping tool.

CRIMP CONNECTION (CRIMP TERMINATION)

The permanent, non-detachable and solder-free mounting of a contact to a conductor via deforming or shaping under pressure to make a good electrical and mechanical connection. Executed with crimping tool, press or automatic crimping machine (see page [156](#)).

CRIMPING AREA

The specified area of the crimp barrel in which the crimp termination is executed by means of deforming or shaping the barrel under pressure around the conductor.

DEGREE OF POLLUTION

The effect of pollution is factored in as degree of pollution when measuring clearance and creepage distances. Four degrees of pollution are defined for the micro-environment: IEC 60664-1:2007 (VDE 0110-1:2008).

DELIVERY FORM

Connectors can be delivered in assembled form or as individual parts.

DERATING CURVE

See page [167](#).

DERATING MEASUREMENT METHOD IEC 60512-5-2:2002 (DIN EN 60512-5-2:2003)

Measurement method to determine the current-carrying capacity of connectors in consideration of the maximum permissible limit temperature (see page [167](#)).

TECHNICAL TERMS



FIXED CONNECTORS

Intended for mounting on a fixed surface such as a frame, dock, device or wall (with ODU also receptacle or panel-mounted plug).

FREE CONNECTORS

Intended for mounting on free ends of mobile leads and cables (with ODU also connectors, plugs, in-line receptacles).

INSULATOR

Part of a connector which separates conductive parts with different potentials from one another; usually identical to the contact carrier.

KEYING (ORIENTATION)

Arrangement with which differing polarization of otherwise identical connectors prevents interchangeability. This is a good idea if two or more identical connectors are attached to the same device (see also compatible connectors, see pages [39](#), [88](#), [125](#)).

LOWERMOST LIMIT TEMPERATURE

The lowest permissible temperature at which a connector may be operated. At ODU MINI-SNAP, it amounts to $-40\text{ }^{\circ}\text{C}$.

MATING AND DEMATING FORCE

The force required to fully insert or withdraw pluggable elements without the influence of a coupling or locking device.

MATING CYCLES

Mechanical actuation of connectors and plug devices via push and pull action. A mating cycle consists of one insertion and withdrawal action. ODU's standard value for the ODU MINI-SNAP series is 5,000 mating cycles.

MAX. CONTINUOUS CURRENT

The metrologically determined amperage at room temperature (approx. $20\text{ }^{\circ}\text{C}$) which increases the contact temperature to the limit temperature. The values specified in the catalog apply to either individual contacts or completely assembled inserts / modules, as indicated.

NOMINAL SINGLE CONTACT CURRENT LOAD

The current-carrying capacity which each individual contact can be loaded with on its own (see page [167](#)).

NOMINAL VOLTAGE

The voltage which the manufacturer specifies for a connector and relates to the operating and performance features.

OPERATING TEMPERATURE FOR ODU MINI-SNAP

Range between the uppermost and lowermost temperature limits. $-40\text{ }^{\circ}\text{C}$ to $+120\text{ }^{\circ}\text{C}$ (see page [15](#)).

OPERATING VOLTAGE

The nominal voltage of the power source for which the connector is being used. The operating voltage may not be higher than the nominal voltage of the connector.

PCB (A.K.A. "PRINTED CIRCUIT BOARD")

A PCB is a carrier for electronic components. It serves the purposes of mechanical mounting and electrical connection.

PCB TERMINATION

Production of a conductive connection between the PCB and an element in through-hole assembly, THT (through-hole technology).

RATED CURRENT (NOMINAL CURRENT)

See page [167](#).

RATED VOLTAGE

According to IEC 60664-1:2007 (VDE 0110-1:2008) standard "Value of a voltage which is specified by the manufacturer for a component, device or operating medium and relates to the operating and performance features."

SOLDER CONNECTION (SOLDER TERMINATION)

Termination technology in which a molten additional metal (solder) with a lower melting point than the base materials to be connected is used to attach two metallic materials to one another.

TECHNICAL TERMS



TERMINATION CROSS-SECTION

The specified cross-sections correspond to a “fine-wire” conductor structure pursuant to IEC 60228:2004 (VDE 0295:2005; Class 5) or a “fine-wire” conductor structure (7/19 wire) according to AWG (ASTM B258-14).

TERMINATION TECHNOLOGIES

Methods for connecting the leads to the electro-mechanical element, such as solder-free connections pursuant to IEC 60352 (DIN EN 60352): crimp, screw connection etc. or soldering connection (see page [165](#)).

TEST VOLTAGE

The voltage which a conductor can withstand under defined conditions without dielectric breakdown or flashover.

TIGHTNESS IEC 60529:2013 (VDE 0470-1:2014)

See protection classes on page [162](#).

UPPERMOST LIMIT TEMPERATURE

The maximum permissible temperature at which a connector may be operated. It includes contact heating through current-carrying capacity.

With ODU MINI-SNAP Standard TURNTAC contacts, it amounts to +120 °C. Please consult ODU for high-temperature applications.

WIRE

Wires (solid conductors) are available with an insulator sleeve and/or electrical shielding. Cables or conductors may be made up of one or more wires.

GENERAL NOTE

The connectors listed in this catalog are intended for use in high voltage and frequency ranges. Suitable precautionary measures must be taken to ensure that people do not come into contact with live conductors during installation and operation. All entries in this catalog were thoroughly reviewed before printing. ODU reserves the right to make changes based on the current state of knowledge without prior notice without being obliged to provide replacement deliveries or refinements of older designs.



Printed on certified recycled paper.

All dimensions are in mm.
Some figures are for illustrative purposes only. Subject to change without notice. Errors and omissions excepted. We reserve the right to change our products and their technical specifications at any time in the interest of technical improvement. This publication supersedes all prior publications.

ODU MINI-SNAP® SERIES L,K,B / C / 0524 / EN

This publication is also available as a PDF file that can be downloaded from www.odu-connectors.com