

**THROUGH HOLE SOCKET STRIPS**

Straight Socket Strips  
Single-, Dual- & Triple-In-Line

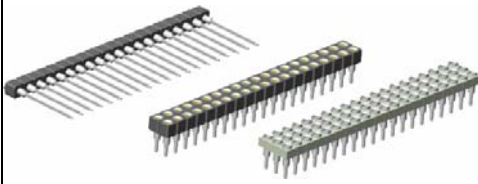

Page 5 to 7

Straight Socket Strips  
Low- & Super Low Profile



Page 17 & 18

90° Socket Strips  
Single- & Dual-In-Line



Page 9

Straight Board Stacker Strips  
Single-, Dual- & Triple-In-Line

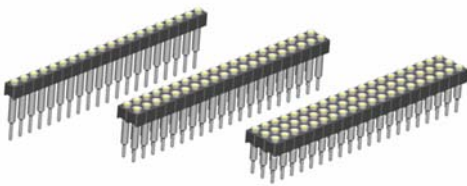

Page 5 & 6

Straight Adapter Strips  
Single-, Dual- & Triple-In-Line

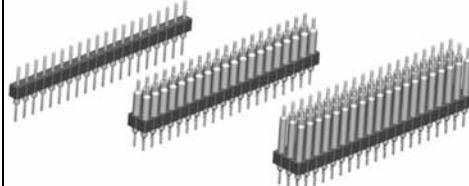

Page 5, 7 & 18

90° Adapter Strips  
Single- & Dual-In-Line



Page 9

**SMT SOCKET STRIPS**

Single- & Dual-In-Line

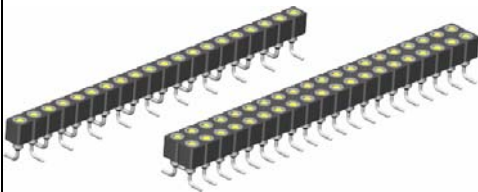

Page 8

Super Low Profile



Page 18

**“F” – CONTACT STRIPS**



Page 28

**JUMBO CONTACT SOCKET & ADAPTER STRIPS**

mating with 0,65x0,65mm square pins (Pin Header)

Single- & Dual-In-Line Socket  
straight & 90° through hole version

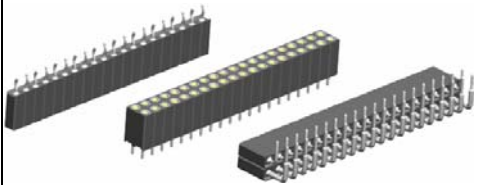

Page 10

Single- & Dual-In-Line Socket  
SMT version

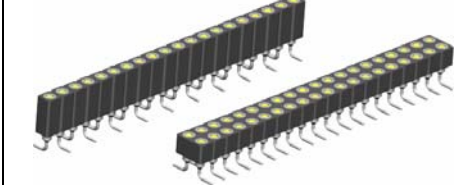

Page 11 & 12

Single- & Dual-In-Line Adapter  
straight & 90° through hole version



Page 13

**Specials**

Crystal Oscillator Sockets

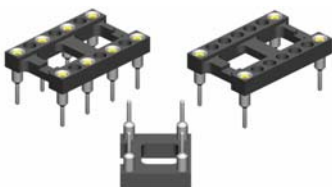

Page 25

Sockets for 7-Segment LED Displays

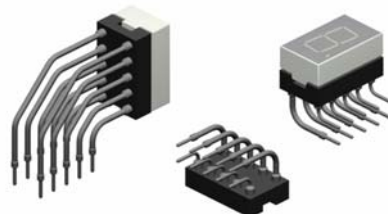

Page 26

Transistor-, TO-Sockets  
& Fuse Holders

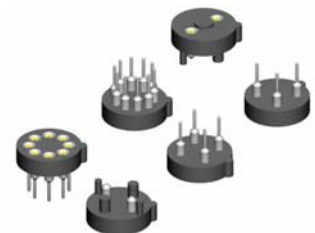

Page 27

**IC DIP SOCKETS THROUGH HOLE STYLE**

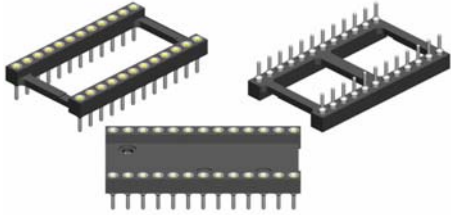
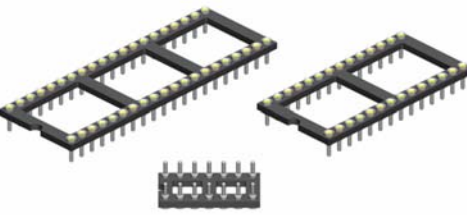
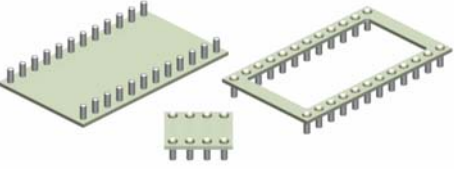
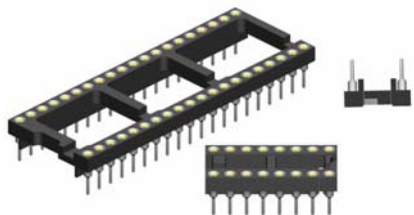
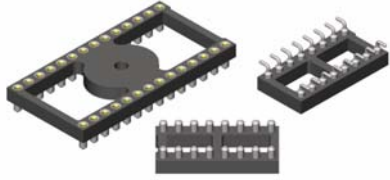
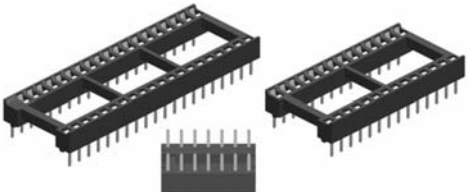
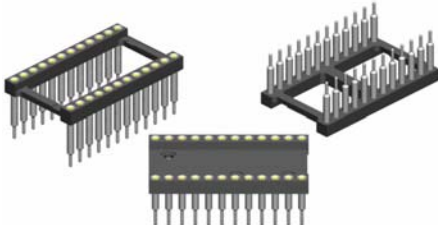
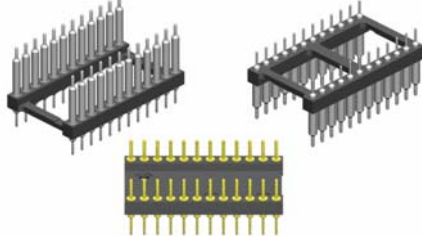
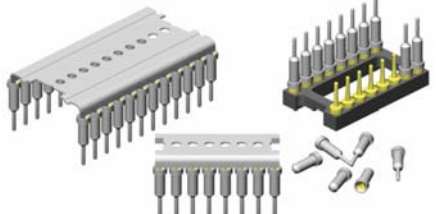
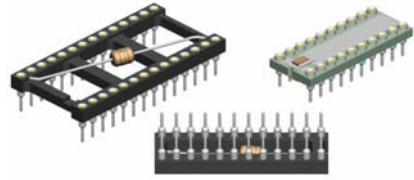
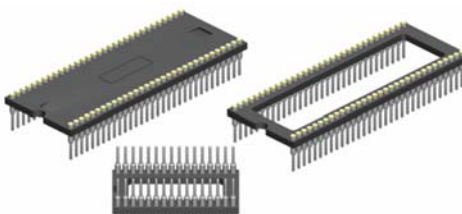
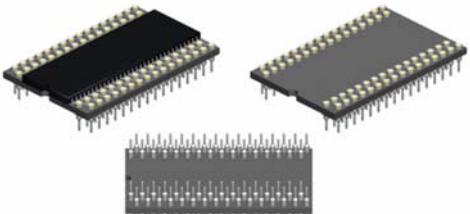
<p>Precision Contact open &amp; closed frame</p>  <p><b>Page 14</b></p>	<p>Precision Contact Low Profile</p>  <p><b>Page 17</b></p>	<p>Precision Contact Super Low Profile</p>  <p><b>Page 18</b></p>
<p>Precision Contact Socket for automatic insertion</p>  <p><b>Page 19</b></p>	<p>SMT Precision Contact</p>  <p><b>Page 21</b></p>	<p>Low Cost - stamped Contact</p>  <p><b>Page 23</b></p>
<p>Precision Contact Board Stacker open &amp; closed frame</p>  <p><b>Page 15</b></p>	<p>Precision Contact Board Spacer open &amp; closed frame</p>  <p><b>Page 16</b></p>	<p>Carrier Sockets</p>  <p><b>Page 20</b></p>
<p>Capacitor Sockets</p>  <p><b>Page 22</b></p>	<p>Shrink Sockets</p>  <p><b>Page 24</b></p>	<p>Quad-In-Line Sockets</p>  <p><b>Page 25</b></p>

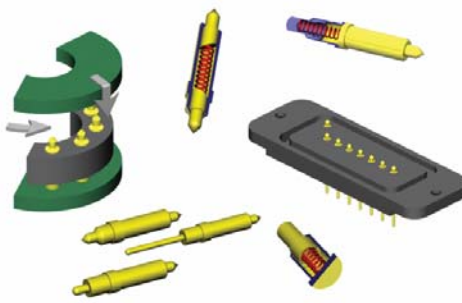
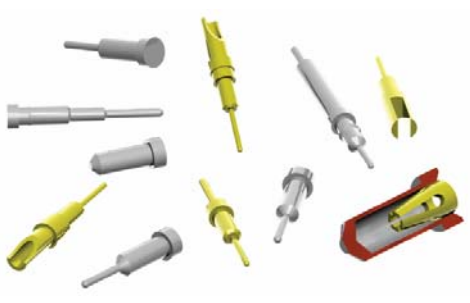
<p><b>TOOLS</b></p>	<p><b>PROBE PINS PROBE PIN CONNECTORS</b></p>	<p><b>TERMINALS</b></p>
 <p><b>Page 44</b></p>	 <p><b>Page 45</b></p>	 <p><b>Page 46 to 48</b></p>

**PIN GRID ARRAY SOCKETS & ADAPTERS**

MiniGrid Sockets & Adapter  
pitch 0.80 – 1.00 – 1.50 – 2.00mm

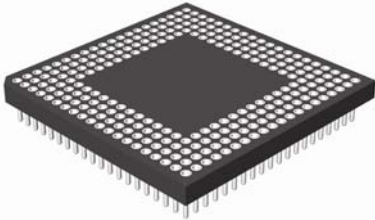

Page 32

Sockets  
pitch 1.27 & 2.54mm  
and Interstitial (2.54mm/1.27mm)

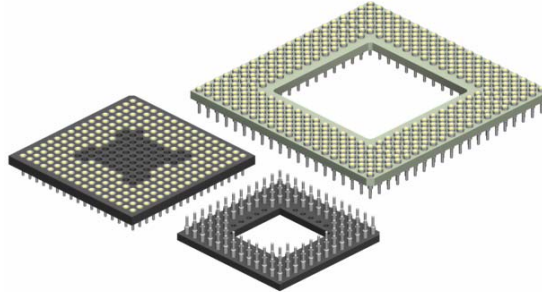

Page 29 to 31

Adapter  
pitch 1.27 & 2.54mm  
and Interstitial (2.54mm/1.27mm)

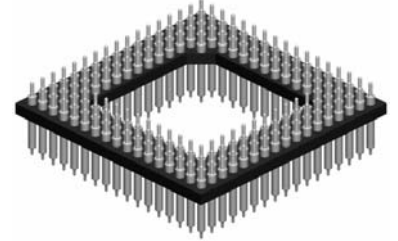

Page 31 & 32

**LCC & PLCC SOCKETS**

Socket for LCC JEDEC Type “C”

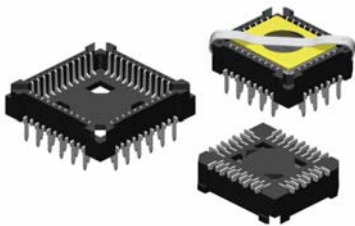

Page 33

Socket for PLCC Chips  
through hole “Commercial” Type

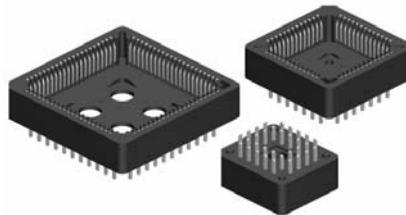

Page 34

Socket for PLCC Chips  
through hole “Hi-Rel” Type

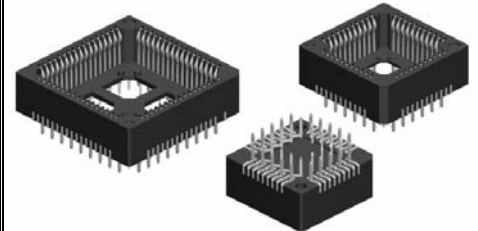

Page 35

Socket for PLCC Chips  
SMT “Hi-Rel” Type

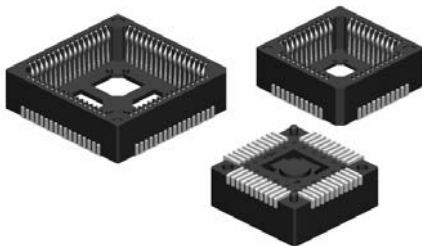

Page 36

Socket for PLCC Chips  
SMT “Low Profile” Type

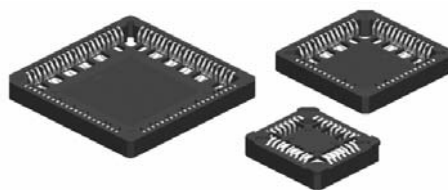

Page 37

Special PLCC Parts  
Adapter & Wire Wrap Adapter

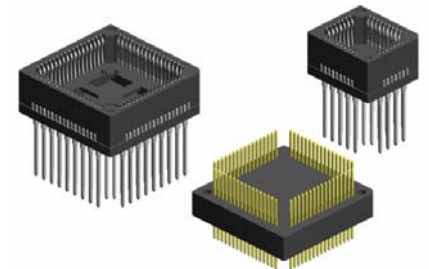

Please ask E-tec for availability

**SIMM SOCKETS**

Vertical & 26° slanted Type  
72- & 80-pin



Page 38

**DIMM SOCKETS**

Vertical Type  
100- , 168- , 184-pin



Page 39, 40 & 43

25° slanted Type  
168-pin



Page 41

90° right angle Type  
168-pin



Page 42

Socket Strips

2,54mm pitch

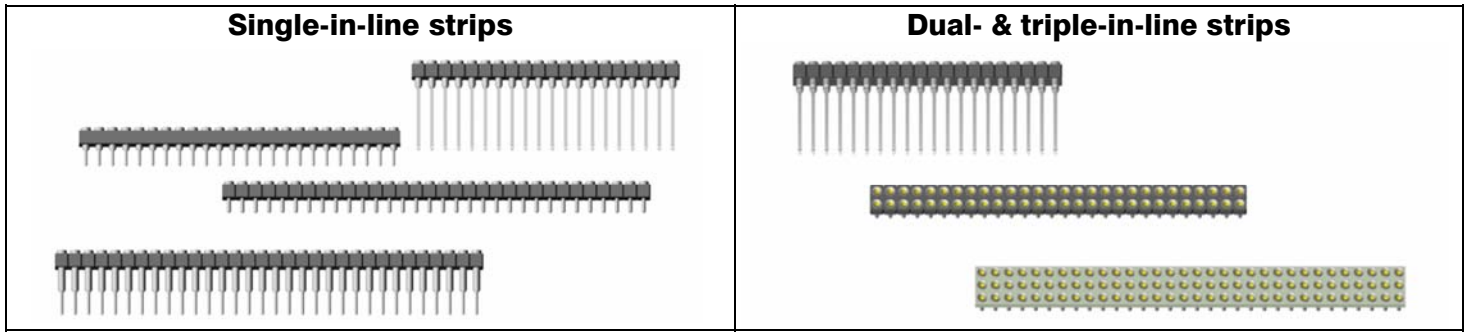

**SIB Series**  
single-in-line Strips  
breakable and solid insulator available  
**Unless otherwise specifically requested, the strips will be delivered either in solid or breakable plastic depending on availability of the insulator bodies.**

**"head flush"**      **"head above"**

**SIB Series**  
**Standard "head flush"**  
**SIB-1xx-Fxxx-xx**

**Alternative: "head above"**  
**SIB-1xx-Sxxx-xx**

Number of contacts standard breakable sizes  
**20; 32 and 40**

Number of contacts either breakable or solid available  
from **02 to 40**

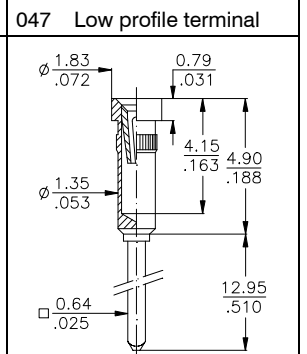
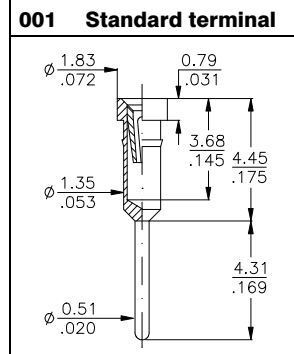
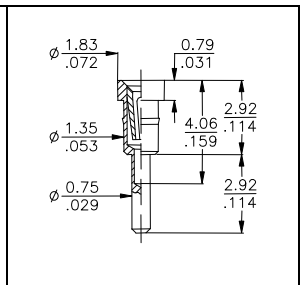
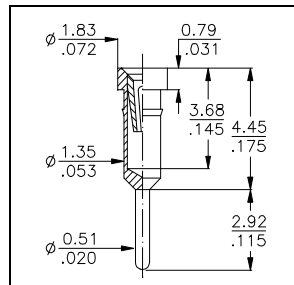

**DIS & TIS Series**  
dual and triple row 2,54mm grid

**DIS Series**  
**DIS-2xx-Fxxx-xx**

Number of contacts available  
from **04 to 80**

**TIS Series**  
**TIS-3xx-Exxx-xx**

Number of contacts available  
from **06 to 96**

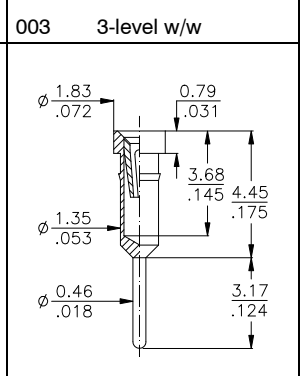
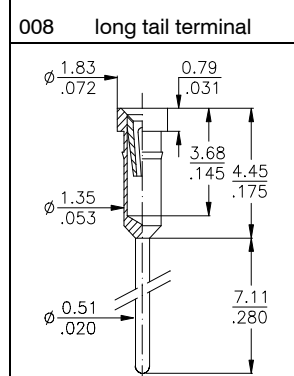

**Strips**  
Other lengths & pin-outs available on request.

**Specifications**  
refer to page 49 of this catalogue

**Terminals**  
For other terminal styles please refer to the pages 46 to 48 of this catalogue or contact your closest sales office.

How to order

XXX - xxx - X xxx - xx

<b>Series</b> SIB = single-in-line strips DIS = dual-in-line strips... TIS = triple-in-line strips...	<b>Rows</b> ..... 1 ..... 2 ..... 3	<b>Nbr of contacts</b> see above table	<b>Insulator</b> F = head flush S = head above E = Epoxy FR4 TIS Series only	<b>Terminal style</b> see drawings above or refer to pages 46 to 48 of this catalogue for other types.	<b>Plating</b> - 95 = tin/gold - 55 = gold/gold - 99 = tin/tin (tin is leadfree)
--	--	---	--	--	--

Board Stacker Strips

2,54mm pitch

**Board Stacker Terminals**

<p><b>079</b></p>	<p><b>623</b></p>	<p><b>062</b></p>
<p><b>060</b></p>	<p><b>063</b></p>	<p><b>080</b></p>
<p><b>084</b></p>	<p><b>085</b></p>	<p><b>088</b></p>
<p><b>065</b></p>	<p><b>Many other terminals and custom specific terminal styles are available on request, or refer to the pages 46 to 48 of this catalogue.</b></p>	

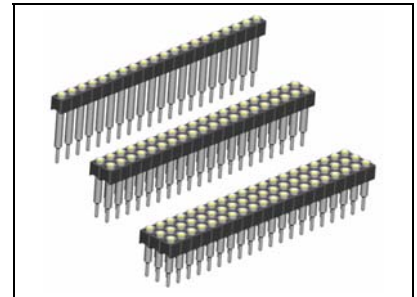

**Application Examples**

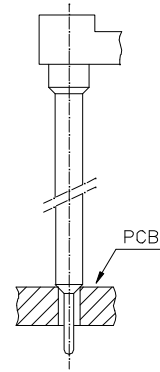

Possible Terminals:

060; 062; 063; 065; 079  
080; 084; 085; 088; 623

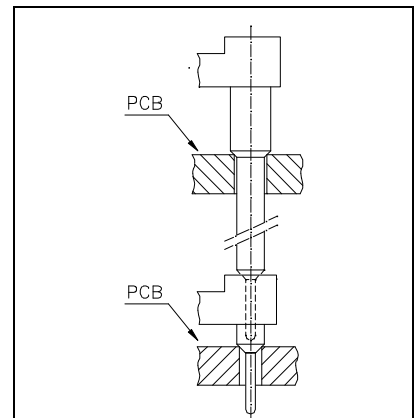

Possible Terminals:

060; 062; 063; 079; 623

**Specifications**

See page 49 of this catalogue

How to order

**XXX - xxx - X xxx - 95**

<p><b>Series</b>  <b>SIB</b> = single-in-line strips.  <b>DIS</b> = dual-in-line strips...  <b>TIS</b> = triple-in-line strips...</p>	<p><b>Rows</b>          ..... <b>1</b>          ..... <b>2</b>          ..... <b>3</b></p>	<p><b>Nbr of contacts</b>          1-row = 02 to 40          2-row = 04 to 80          3-row = 06 to 96</p>	<p><b>Insulator</b>          see socket strip page 5</p>	<p><b>Terminal style</b>          see drawings above or refer to pages 46 to 48 of this catalogue for other types.</p>	<p><b>Plating</b>          - <b>95</b> = tin/gold (tin leadfree)          other on request</p>
---	--	---	--	--	--

Adapter Strips

2,54mm pitch

**Board to Board Terminals**

<p>077</p>	<p>057</p>	<p>037</p>
<p>058</p>	<p>059</p>	<p>056</p>
<p>542</p>	<p>038</p>	<p>353</p>
<p>036</p>	<p><b>Many other terminals and custom specific terminal styles are available on request, or refer to the pages 46 to 48 of this catalogue.</b></p>	

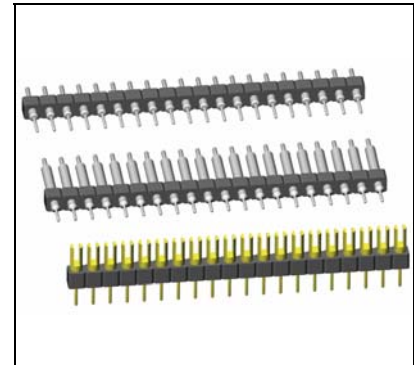

**Application Examples**

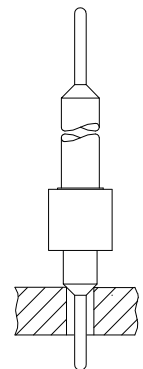

**Possible Terminals:**  
 037; 056; 057; 058; 059  
 077; 220; 542; 544  
 562; 583; 770

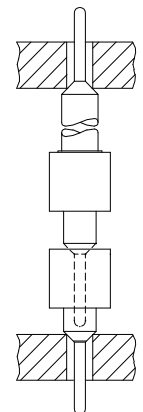

**Possible Terminals:**  
 037; 056; 057; 058; 059  
 077; 078; 542; 544  
 562; 583; 770

How to order

XXX - x xx - X xxx - xx

<p><b>Series</b></p> <p><b>SIB</b> = single-in-line strips.  <b>DIS</b> = dual-in-line strips...  <b>TIS</b> = triple-in-line strips..</p>	<p><b>Rows</b></p> <p>.....1                  .....2                  .....3</p>	<p><b>Nbr of contacts</b></p> <p>1-row = 02 to 40                  2-row = 04 to 80                  3-row = 06 to 96</p>	<p><b>Insulator</b></p> <p><b>S</b> = Plastic  <b>E</b> = Epoxy FR4                  (TIS Series only)                  dimension see socket strip page 5</p>	<p><b>Terminal style</b></p> <p>see drawings above                  or refer to pages 46 to 48 of this catalogue for other types.</p>	<p><b>Plating</b></p> <p>- 55 = gold                  - 99 = tin (leadfree)</p>
--	--	---	---	---	---

SMT Socket Strips 2,54mm pitch

The 2,54mm pitch **SMT** socket strips with standard IC-Socket Precision Contacts can also be used in combination with the straight version SIB/DIS strips shown earlier in this catalogue.

The socket strips accept round pins with a diameter of 0,41 to 0,56mm max., as well as square pins of 0,40 x 0,40mm max.

The **SMT** socket strips are available in single and dual row.

The head of the female terminal is completely embedded in the insulator.

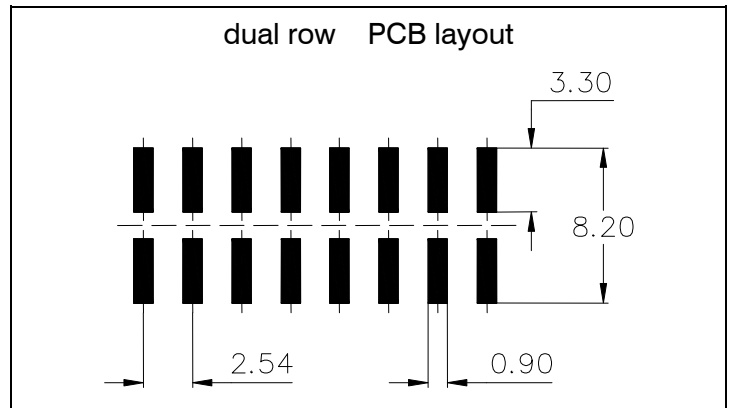
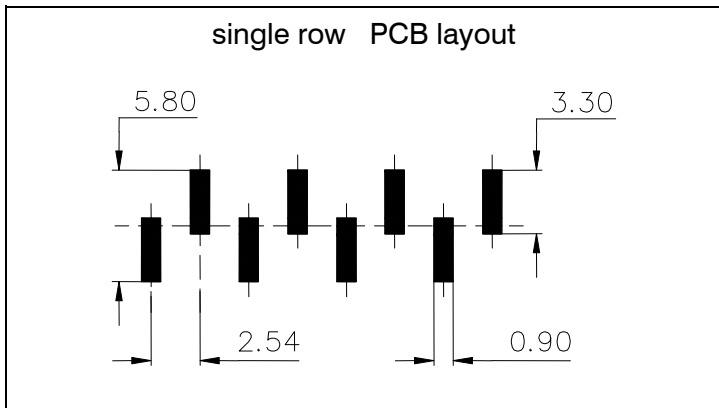
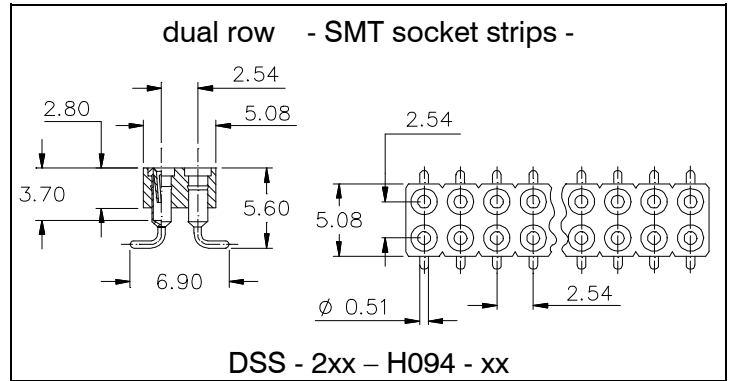
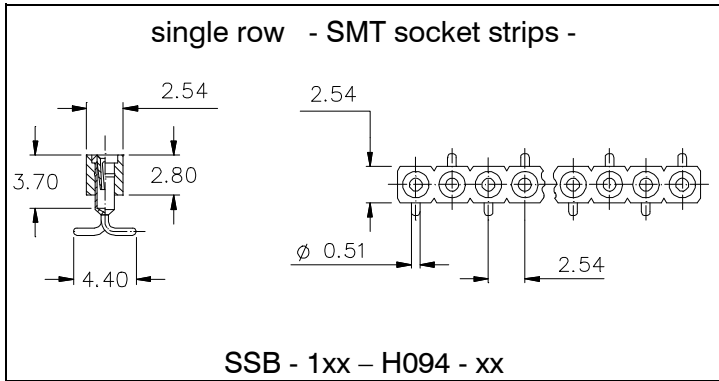
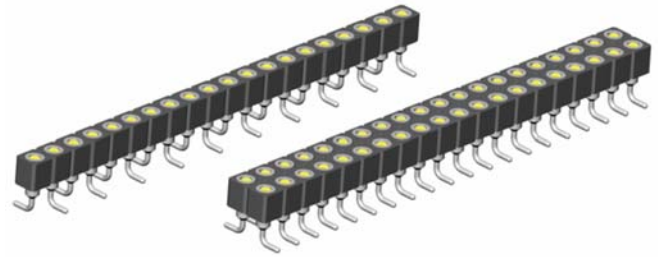

Specifications

**Mechanical data**

Insertion force contact type 900	1,80 N (avg)
Extraction force contact type 900	0,90 N (avg)
Contact life	> 100 cycles
Operating temperature	-55° C to +125° C
Processing temperature	+250°C +0/-5°C for 20~40sec.

**Material**

Insulator (RoHS compliant)	high temp plastic UL 94 V-0
Terminal (RoHS compliant)	CuZn
Contact (RoHS compliant)	BeCu

**Electrical data**

Insulation resistance	5 x 10 <sup>9</sup> Ω min.
Breakdown voltage	500 V AC for 1 minute
Contact resistance	4,3 mΩ typ.
Current rating	1 A max., 100V

**Insertion depth contact type 900**

maximum	3,68mm / .145"
minimum	2,80mm / .110"

How to order

XXX - x xx - H 094 - xx

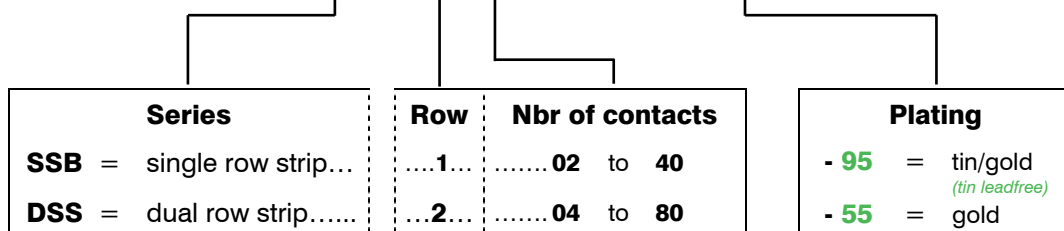

# 90° Socket Strips & Male Headers

The 2,54mm pitch 90° socket strips and male headers are designed for „board to board“ connections, and can also be used in combination with the straight version SIB/DIS strips shown earlier in this catalogue.

The socket strips accept round pins with a diameter of 0,41 to 0,56mm max., as well as square pins of 0,40 x 0,40mm max.

The socket strips and male headers are stackable and available in any pinout as shown in the below order code.

The head of the female terminal is completely embedded in the insulator.

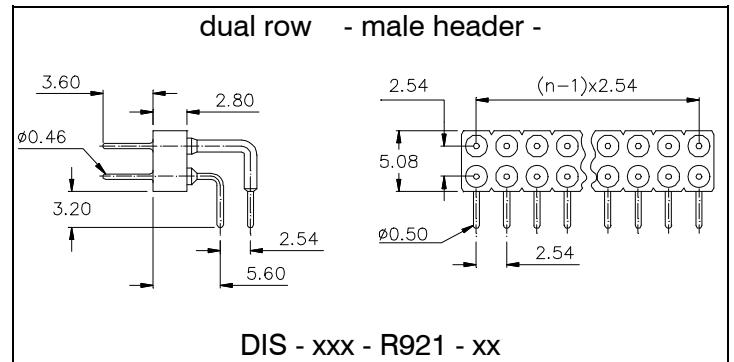
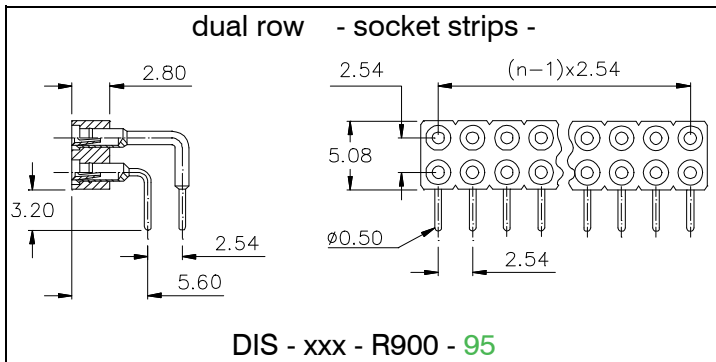
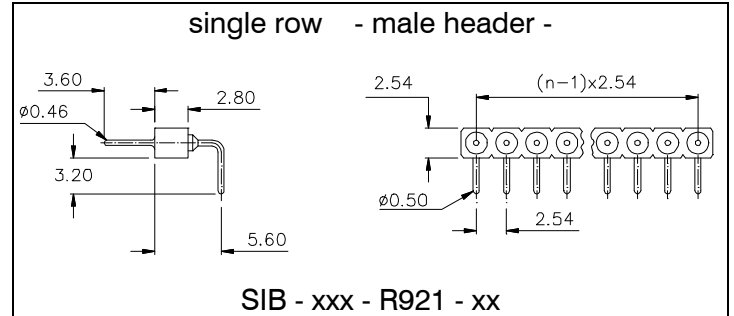
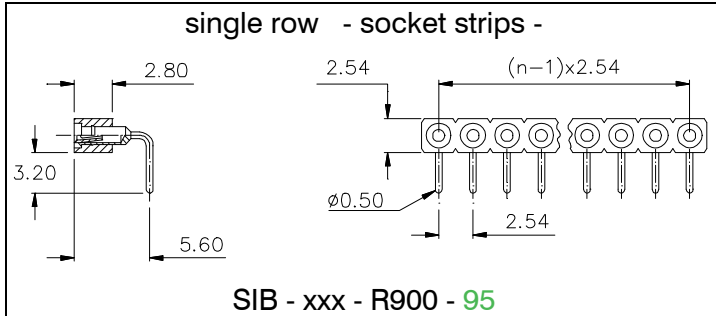
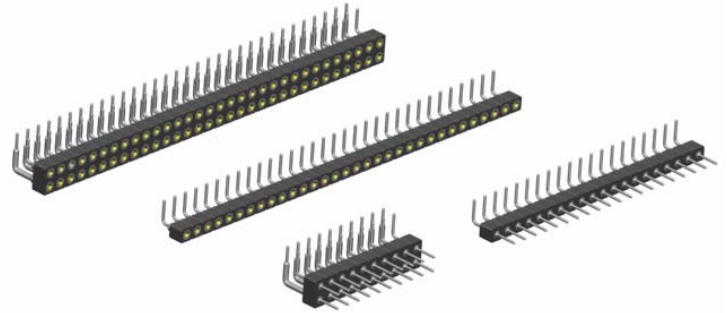

## Specifications

**Mechanical data**

Insertion force contact type 900	1,80 N (avg)
Extraction force contact type 900	0,90 N (avg)
Contact life	> 100 cycles
Operating temperature	-55° C to +125° C
Processing temperature	+250°C +0/-5°C for 20~40sec.

**Material**

Insulator (RoHS compliant)	high temp plastic UL 94 V-0
Terminal (RoHS compliant)	CuZn
Contact (RoHS compliant)	BeCu

**Electrical data**

Insulation resistance	5 x 10 <sup>9</sup> Ω min.
Breakdown voltage	500 V AC for 1 minute
Contact resistance	4,3 mΩ typ.
Current rating	1 A max., 100V

**Insertion depth contact type 900**

maximum	3,68mm / .145"
minimum	2,80mm / .110"

How to order

**XXX - xxx - R xxx - xx**

Series	Row	Nbr of contacts	Contact Type	Plating
<b>SIB</b> = single-in-line strips	... 1	<b>02 to 40</b> <i>20, 32, 40 Std. breakable sizes</i>	<b>900</b> = female	<b>Contact type „900“</b> - <b>95</b> = tin/gold (tin leadfree)
<b>DIS</b> = dual-in-line strips...	... 2	<b>04 to 72</b>	<b>921</b> = male	<b>Contact type „921“</b> - <b>99</b> = tin (tin leadfree) - <b>55</b> = gold

2,54mm pitch female header with precision „Jumbo Contact“ for board to board connections.

Accepts **square pins 0,65 x 0,65mm** max. (Pin Headers), as well as **round pins Ø 0,65 to 0,85mm** max.

7,00mm standard profile, and 4.50mm low profile available, other on request.

The stand-offs underneath the insulator, prevent the header from slanting during soldering.

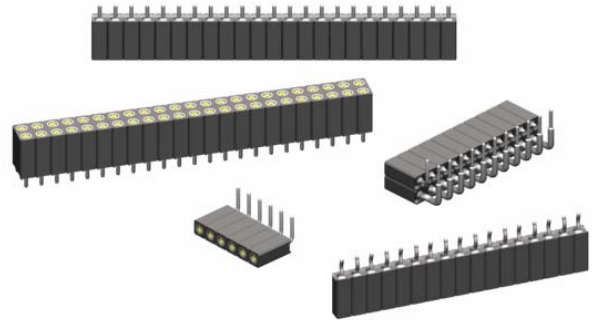

<p><b>4.50mm Profile</b> single row -straight-</p> <p><b>BL1 - xxx - G109 - 95</b></p>	<p><b>7.00mm Profile</b> single row -straight-</p> <p><b>BL1 - xxx - G700 - 95</b></p>	<p><b>Other available Terminals</b></p> <p><b>G065P press fit type</b> For PCB thickness 1.50 to 2.00mm; plated-thru holes: Ø0,94 to 1,09mm</p>	<p>single row -right angle-</p> <p><b>BL1 - xxx - A700 - 95</b></p>
<p><b>4.50mm Profile</b> dual row -straight-</p> <p><b>BL2 - xxx - G109 - 95</b></p>	<p><b>7.00mm Profile</b> dual row -straight-</p> <p><b>BL2 - xxx - G700 - 95</b></p>	<p><b>G799 Clinched type</b> off G700 only for BL1 Series available</p>	<p>dual row -right angle-</p> <p><b>BL2 - xxx - A700 - 95</b></p>

**Specifications**

**Mechanical data**

Insertion force (test probe Ø 0,66) 1,40 N (avg) if A700, G700 & G109  
 2,00 N (avg) if G065P  
 3,75 N (avg) if G799  
 Extraction force (test probe Ø 0,66) 0,25 N (avg) if A700, G700 & G109  
 1,00 N (avg) if G065P & G799  
 Contact life > 100 cycles  
 Operating temperature -55° C to +125° C

**Material**

Insulator (RoHS compliant) high temp plastic UL 94 V-O  
 Terminal (RoHS compliant) CuZn  
 Contact (RoHS compliant) BeCu

**Electrical data**

Insulation resistance 10<sup>4</sup> MΩ min.  
 Breakdown voltage 500 V AC for 1 minute  
 Contact resistance 30 mΩ / contact max.  
 Current rating 3 A max., 100V  
**Insertion depth**  
 maximum depends on the Terminal style  
 minimum 4,00mm / .157"

How to order

**BLx - xxx - X xxx - 95**

<p><b>Series</b>  <b>BL1</b> = single row...  <b>BL2</b> = dual row....</p>	<p><b>Nbr of contacts</b>                  .....002 to 050  <i>Note: 002 to 040 only available for G109 series</i>                  .....004 to 100  <i>Note: 004 to 080 only available for G109 series</i></p>	<p><b>Connector style</b>  <b>G</b> = straight  <b>A</b> = right angle</p>	<p><b>Terminal Type</b>                  pls. ref. to the drawings shown above                  "press fit" = 065P and "clinched" type = 799                  not available for the <b>A</b> = right angle style</p>	<p><b>Plating</b>                  - 95 = tin/gold (tin leadfree)                  others on request</p>
---	---	--	--	--

2,54mm pitch **SMT** female header with precision „Jumbo Contact“ for board to board connections.

Accepts square pins 0,65 x 0,65mm max. (Pin Headers), as well as round pins  $\varnothing$  0,65 to 0,85mm max.

The female headers are available in any number of contacts, up to a maximum of 50 for the single row, and 100 for the double row.

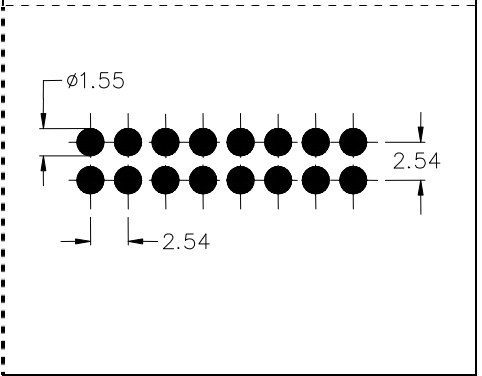
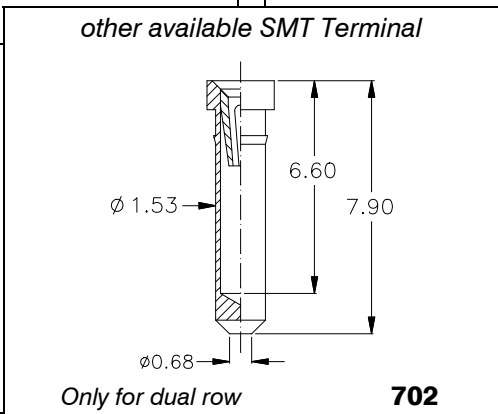
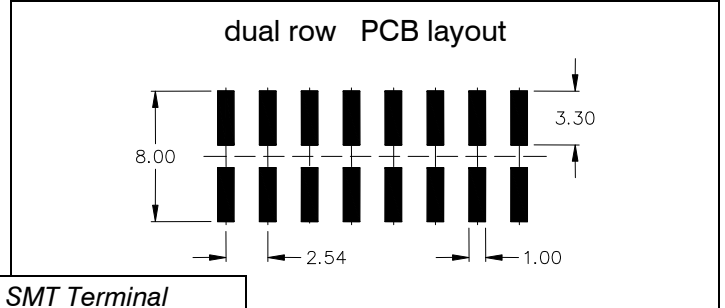
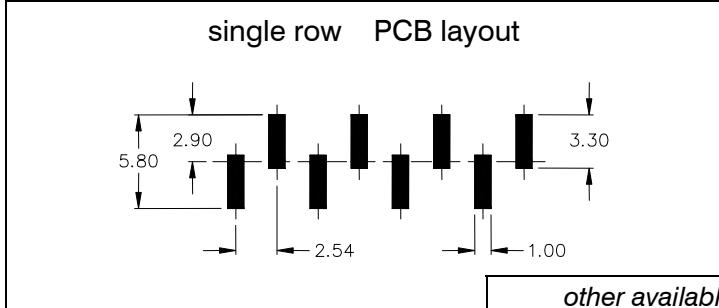
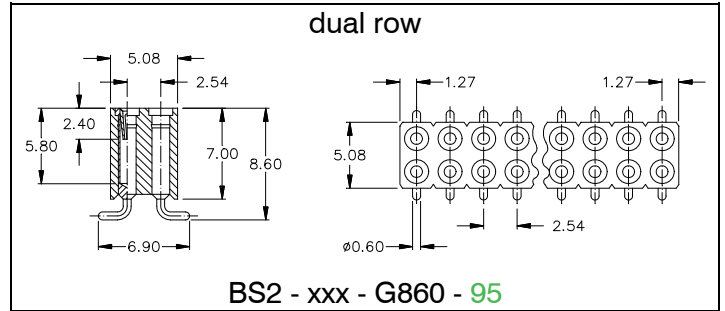
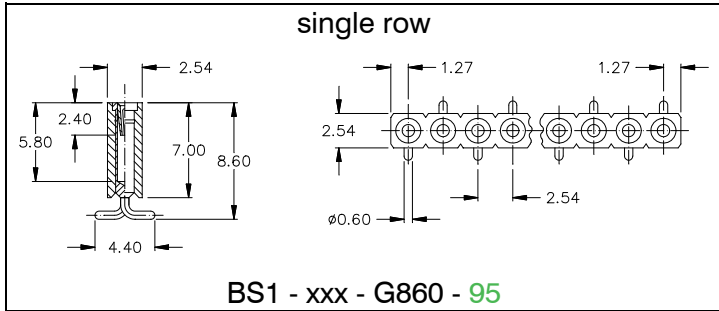
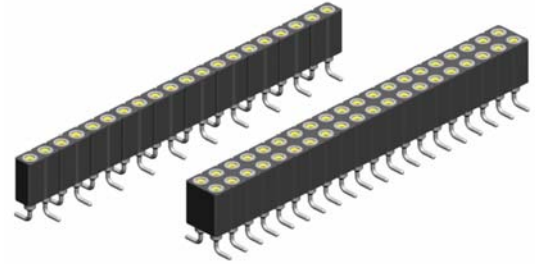

**Specifications**

**Mechanical data**

Insertion force (test probe $\varnothing$ 0,66)	2,00 N if Terminal 860
Extraction force (test probe $\varnothing$ 0,66)	1,00 N for all Terminals
Contact life	> 100 cycles
Operating temperature	-55° C to +125° C
Processing Temperature	+250°C +0/-5°C for 20~40sec.

**Material**

Insulator	(RoHS compliant) high temp plastic UL 94 V-0
Terminal	(RoHS compliant) CuZn
Contact	(RoHS compliant) BeCu

**Electrical data**

Insulation resistance	10 <sup>4</sup> M $\Omega$ min.
Breakdown voltage	500 V AC for 1 minute
Contact resistance	30 m $\Omega$ / contact max.
Current rating	3 A max., 100V

**Insertion depth**

maximum	depends on the Terminal style
minimum	4,0mm / .157"

**How to order**

**BSX - xxx - G xxx - xx**

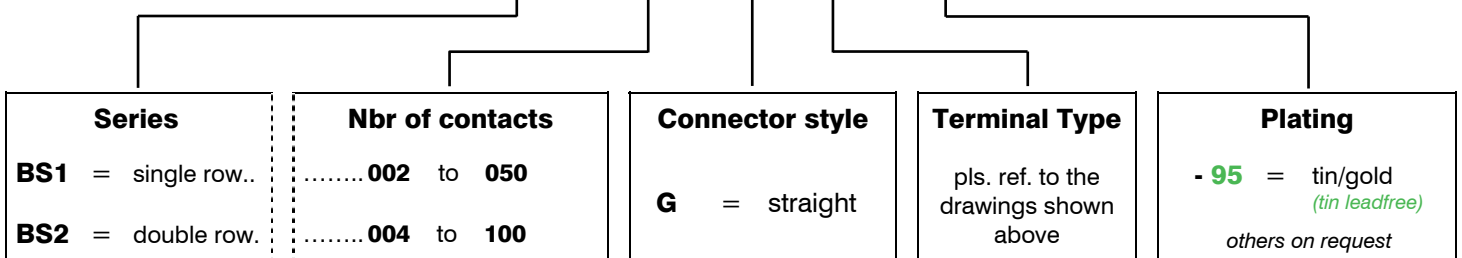

2,54mm pitch “low profile” SMT female header with precision „Jumbo Contact“ for board to board connections.

Accepts square pins 0,65 x 0,65mm max. (Pin Headers), as well as round pins  $\varnothing$  0,65 to 0,85mm max.

The female headers are available with 40 contacts max. for the single row, and 80 (2x40) max. for the dual row.

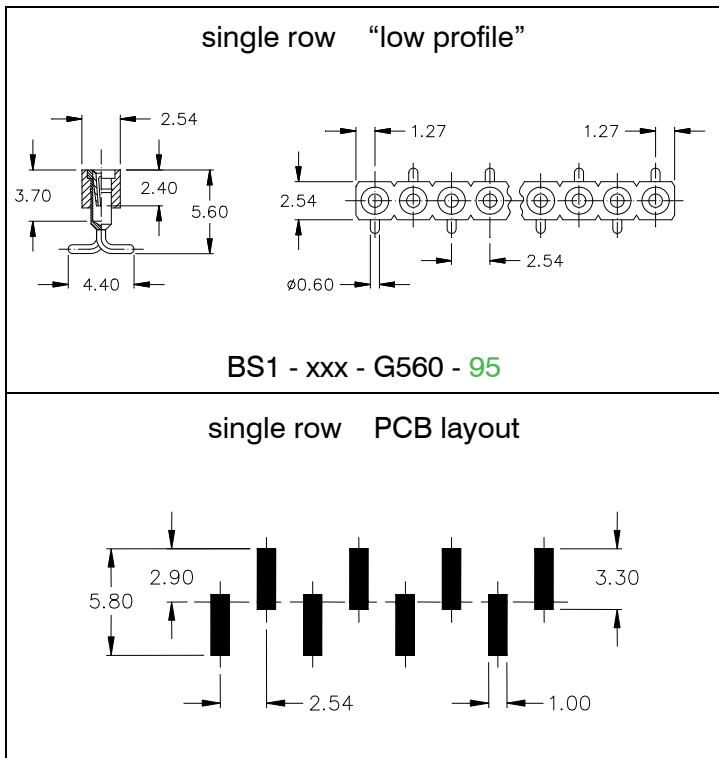
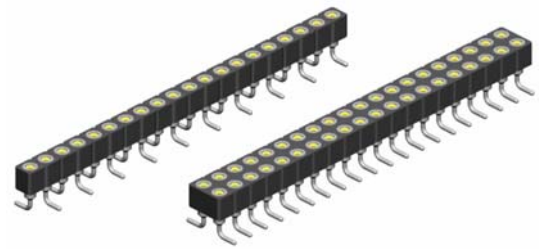

### Specifications

**Mechanical data**

Insertion force	1,40 N (avg) (test probe $\varnothing$ 0,66)
Extraction force	0,25 N (avg) (test probe $\varnothing$ 0,66)
Contact life	> 100 cycles
Operating temperature	-55° C to +125° C
Processing Temperature	+250°C +0/-5°C for 20~40sec.

**Material**

Insulator	(RoHS compliant) high temp plastic UL 94 V-O
Terminal	(RoHS compliant) CuZn
Contact	(RoHS compliant) BeCu

**Electrical data**

Insulation resistance	10 <sup>4</sup> M $\Omega$ min.
Breakdown voltage	500 V AC for 1 minute
Contact resistance	30 m $\Omega$ / contact max.
Current rating	3 A max., 100V

**Insertion depth**

maximum	3.70mm / .146"
minimum	3.00mm / .118"

How to order

**BSx - xxx - G560 - 95**

<b>Series</b>	<b>Nbr of contacts</b>	<b>Connector style</b>	<b>Terminal Type</b>	<b>Plating</b>
BS1 = single row..	..... 002 to 040	G = straight	pls. ref. to the drawings shown above	- 95 = tin/gold (tin leadfree) others on request
BS2 = dual row....	..... 004 to 080			

# SL - Series „Jumbo“ Male Headers

2,54mm pitch



2,54mm pitch male header with precision turned „Jumbo“ pin,  $\varnothing$  0,76mm / .030“, for board to board connections.

Mates with the „Jumbo Contact“ female headers shown in this catalogue.

The pin headers are stackable and available in single and double row version.

The pins are either completely gold or tin plated.

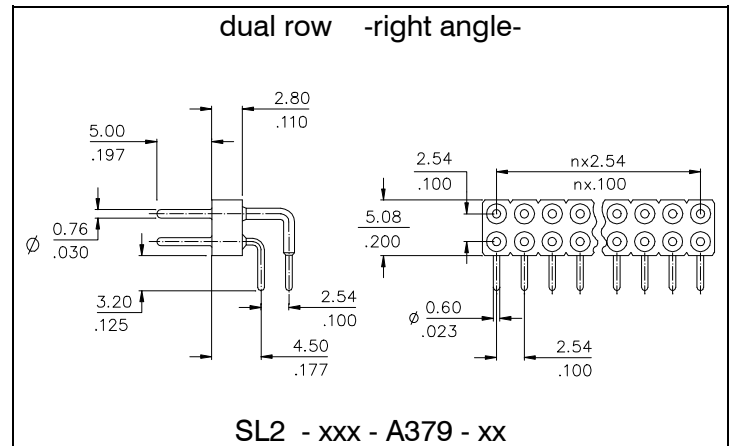
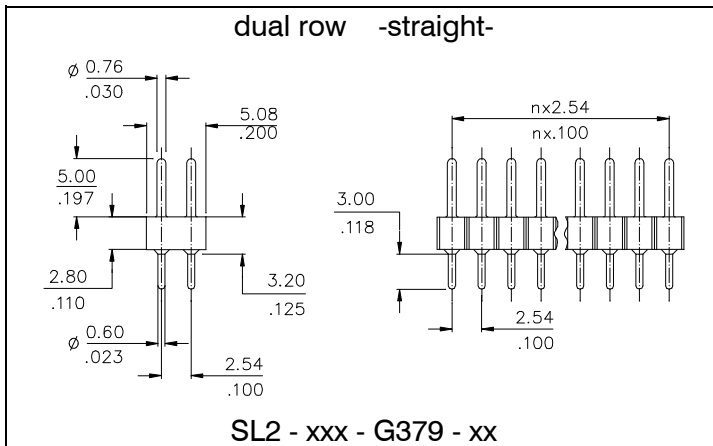
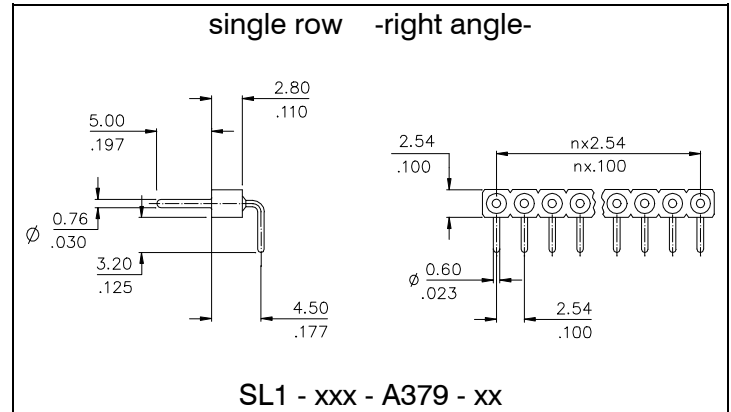
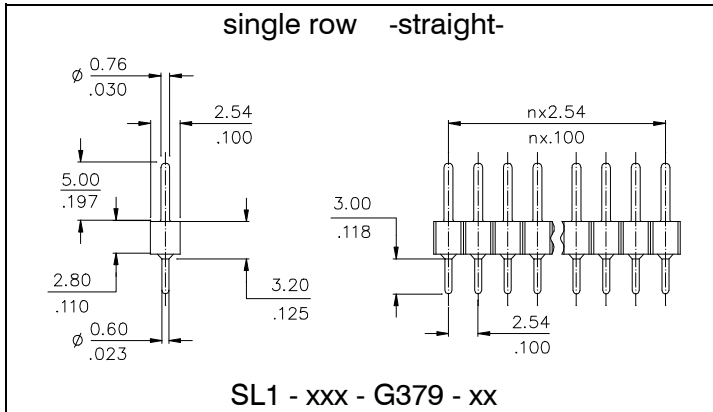
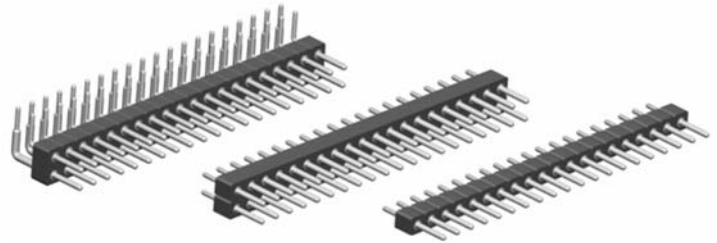

## Specifications

### Material

Insulator (RoHS compliant) high temp plastic UL 94 V-O  
Terminal (RoHS compliant) CuZn

**Operating temperature** -55° C to +125° C

### Electrical data

Insulation resistance 10<sup>4</sup> M $\Omega$  min.  
Breakdown voltage 500 V AC for 1 minute  
Rated voltage 60 V RMS / 90 V DC  
Contact resistance 30 m $\Omega$  / contact max.  
Current rating 3 A max.

### How to order

SLx - xxx - X 379 - xx

Series	
SL1	= single row.....
SL2	= dual row.....

Nbr of contacts	
.....002	to 040
064	on request only
.....004	to 080 (straight style)
.....004	to 072 (right angle style)

Terminal style	
G	= straight
A	= right angle

Plating	
- 99	= tin (tin leadfree)
- 55	= gold

Precision DIP Sockets 2,54mm pitch

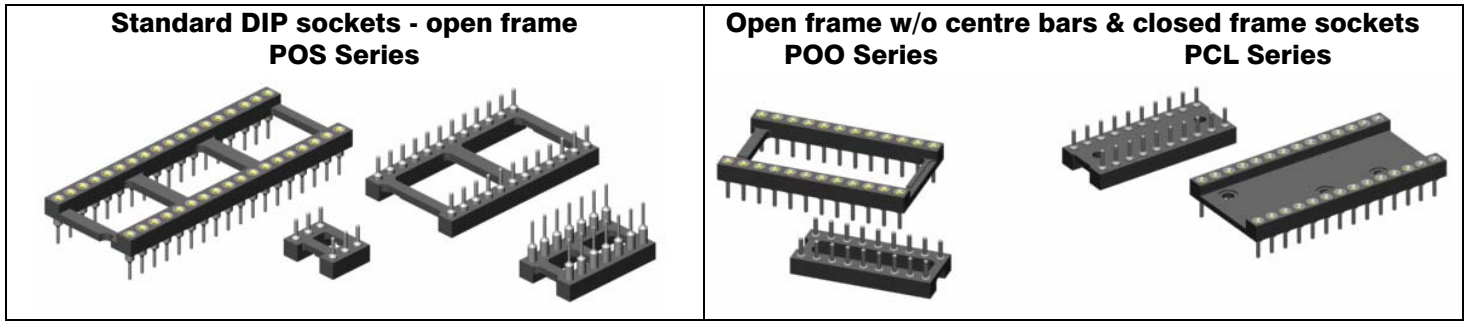

**Series POS & POO**  
- open body with and without centre bars -  
*If you need all Insulator Dimension pls. ask for customer drawing!*

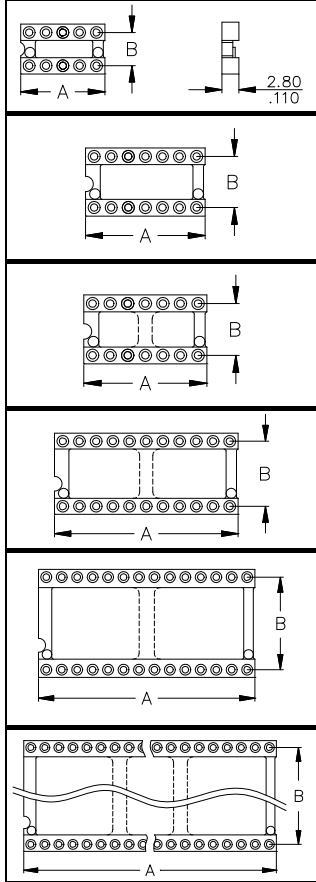

**POS sockets in 7,62mm/.300" DIP spacing are either supplied with or without bars in the centre depending on plastic wafer availability. If you need sockets without centre bars, then please always order with POO instead of POS.**

Pin	Dimension		Available Pinouts of Series		
	"A"	"B"	POS	POO	PCL
10	12,60	5,08 .200"	-	-	<b>-210-</b>
6	7,60	7,62 .300"	<b>-306-</b>	-	-
8	10,10		<b>-308-</b>	-	-
10	12,60		<b>-310-</b>	-	-
14	17,70		<b>-314-</b>	<b>-314-</b>	<b>-314-</b>
16	20,30		<b>-316-</b>	<b>-316-</b>	<b>-316-</b>
18	22,80		<b>-318-</b>	<b>-318-</b>	<b>-318-</b>
20	25,30	7,62 .300"	<b>-320-</b>	<b>-320-</b>	<b>-320-</b>
22	27,80		on request	on request	-
24	30,40		<b>-324-</b>	<b>-324-</b>	-
28	35,50		<b>-328-</b>	<b>-328-</b>	-
16	20,32	10,16 .400"	on request	on request	on request
22	27,80		on request	on request	on request
24	30,60		on request	on request	on request
24	30,50	15,24 .600"	<b>-624-</b>	<b>-624-</b>	on request
28	35,50		<b>-628-</b>	<b>-628-</b>	<b>-628-</b>
32	40,60		<b>-632-</b>	<b>-632-</b>	<b>-632-</b>
36	45,70		<b>-636-</b>	on request	-
40	50,80		<b>-640-</b>	<b>-640-</b>	<b>-640-</b>
48	60,96		<b>-648-</b>	on request	on request
64	81,26	22,86 .900"	on request	-	-

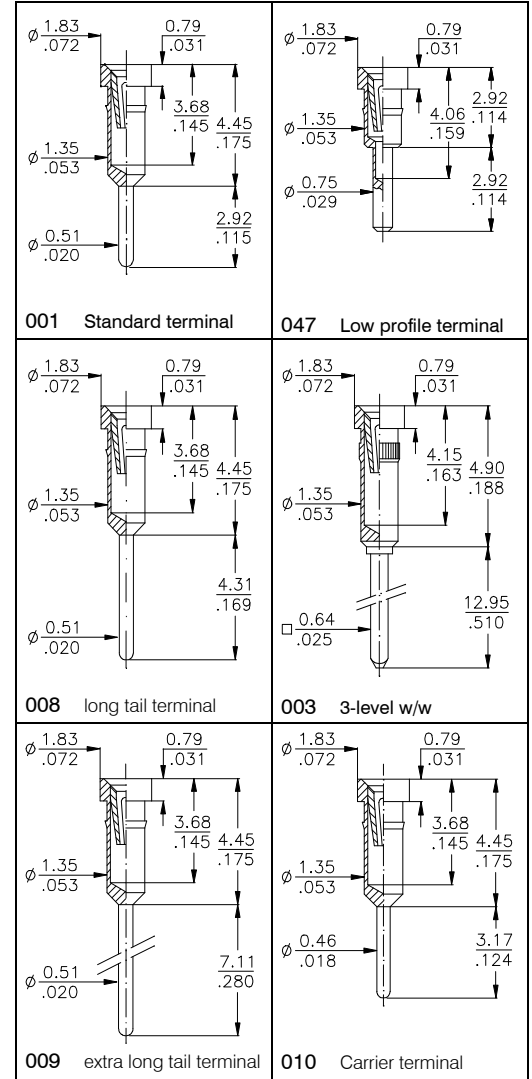

**Specifications**  
PBT and high temp plastic depending on type.  
See page 49 of this catalogue and contact factory for more details.

**Insulator body**  
POS series = open insulator - see drawings above  
POO series = open insulator w/o centre bars  
PCL series = closed insulator body

**Terminals**  
The POS, POO and PCL series are available with many different terminal styles. The most common terminal styles are shown on the right hand side of this page. Many other additional terminals can be found at the end of this catalogue. Custom design terminals are available on request.

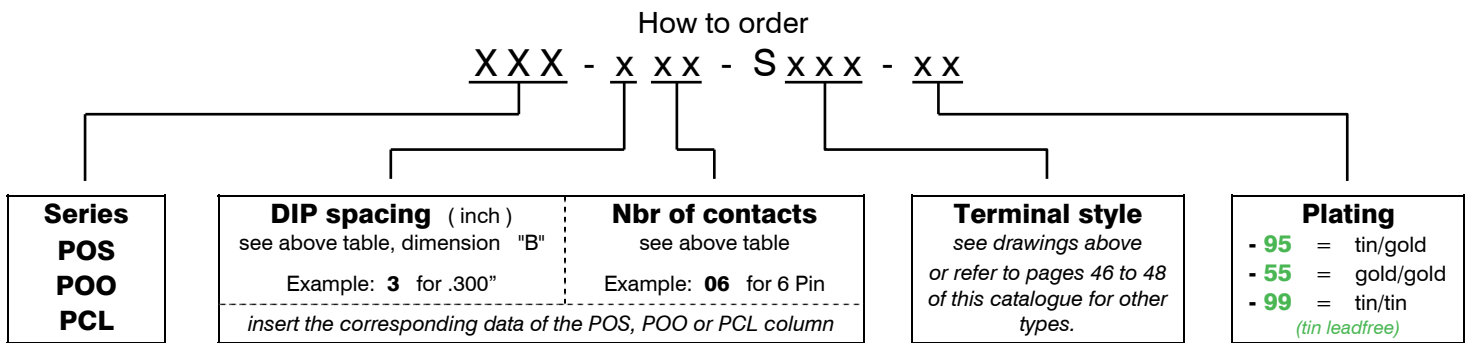

Board Stacker Sockets 2,54mm pitch

**Board Stacker Terminals**

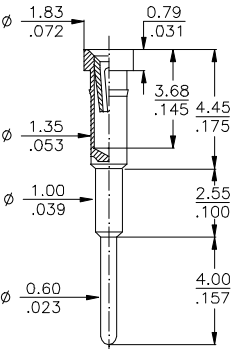
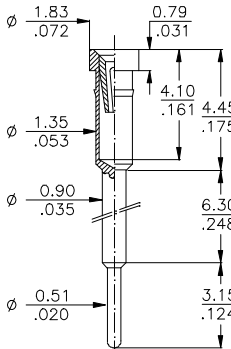
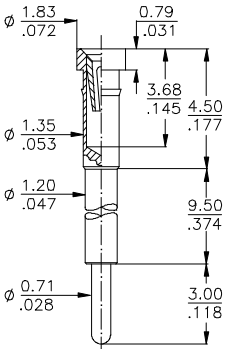
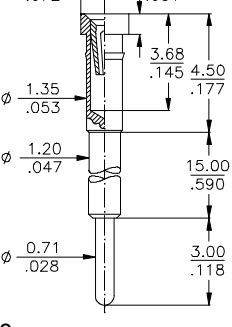
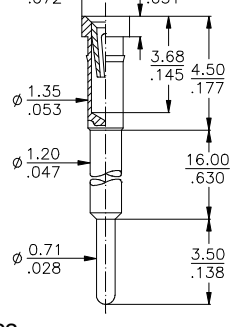
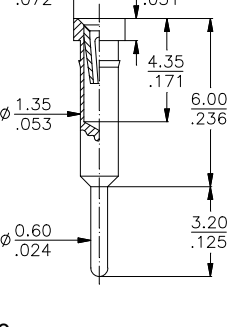
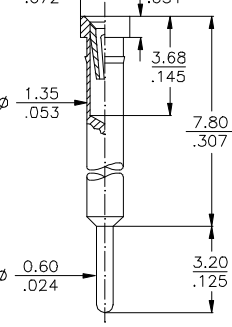
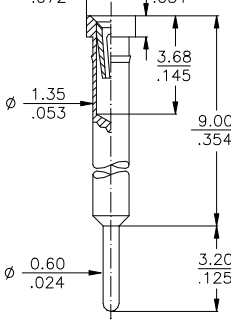
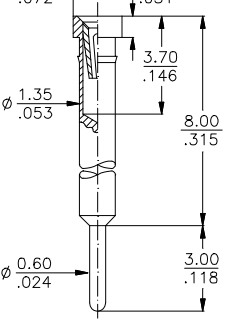
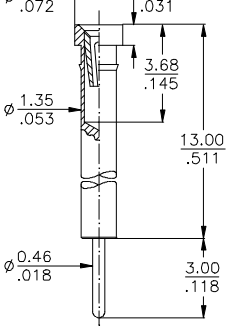
 <p>079</p>	 <p>623</p>	 <p>062</p>
 <p>060</p>	 <p>063</p>	 <p>080</p>
 <p>084</p>	 <p>085</p>	 <p>088</p>
 <p>065</p>	<p><b>Many other terminals and custom specific terminal styles are available on request, or refer to the pages 46 to 48 of this catalogue.</b></p>	

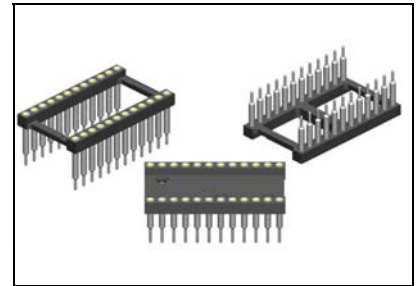

**Application Examples**

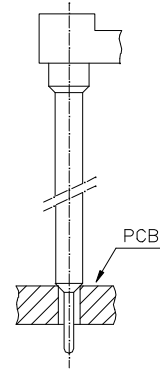

Possible Terminals:

060; 062; 063; 065; 079  
080; 084; 085; 088; 623

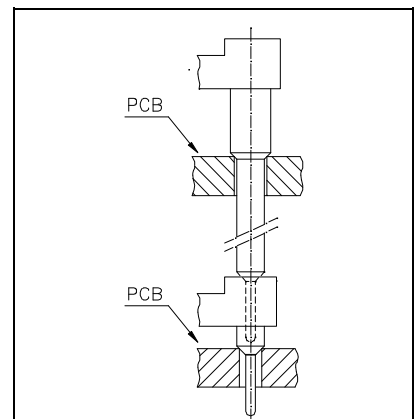

Possible Terminals:

060; 062; 063; 079; 623

**Specifications**

See page 49 of this catalogue

How to order

XXX - x xx - S xxx - xx

<p><b>Series</b> POS POO PCL see page 14</p>	<p><b>DIP spacing</b> in inch refer to table, dimension "B" on page 14</p> <hr/> <p>insert the corresponding data of the POS, POO or PCL column</p>	<p><b>Nbr of contacts</b> refer to table on page 14</p>	<p><b>Terminal style</b> see drawings above or refer to pages 46 to 48 of this catalogue for other types.</p>	<p><b>Plating</b> - 95 = tin/gold (tin leadfree) other on request</p>
--	---	---	---	---

DIP Board Spacer 2,54mm pitch

**Board to Board Terminals**

<p>077</p>	<p>057</p>	<p>037</p>
<p>058</p>	<p>059</p>	<p>056</p>
<p>542</p>	<p>038</p>	<p>353</p>
<p>036</p>	<p><b>Many other terminals and custom specific terminal styles are available on request, or refer to the pages 46 to 48 of this catalogue.</b></p>	

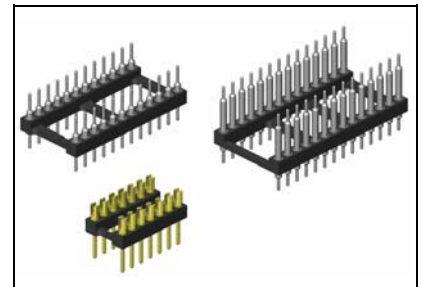

**Application Examples**

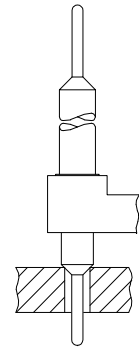

Possible Terminals:

037; 056; 057; 058; 059; 077  
220; 221; 542; 543; 544; 562  
770

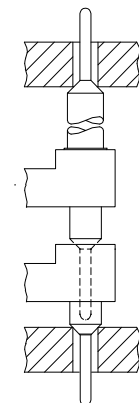

Possible Terminals:

037; 056; 057; 058; 059  
077; 542; 544; 562; 770

**Specifications**

See page 49 of this catalogue

How to order

XXX - xxx - Sxxx - xx

<p><b>Series</b> <b>POS</b> <b>PCL</b> see page 14</p>	<p><b>DIP spacing</b> in inch refer to table, dimension "B" on page 14  insert the corresponding data of the POS, POO or PCL column</p>	<p><b>Nbr of contacts</b> refer to table on page 14</p>	<p><b>Terminal style</b> see drawings above or refer to pages 46 to 48 of this catalogue for other types.</p>	<p><b>Plating</b> - 55 = gold - 99 = tin (tin leadfree)</p>
--	---	---	---	---

“low profile“ Sockets & Strips

**Low profile DIP sockets LOP Series**

height above PCB 2.41mm / .095"

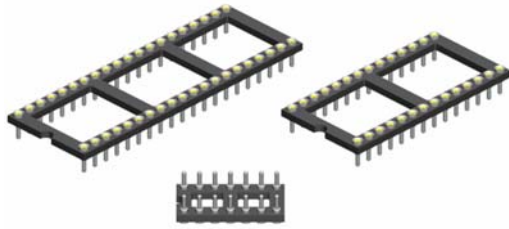

**Low profile strips SLP Series**

height above PCB 2.41mm / .095"

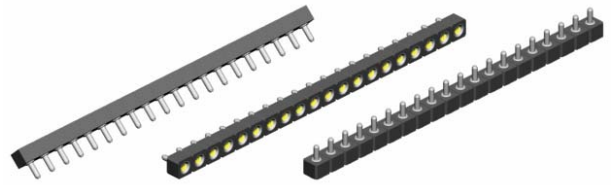

**Insulator**

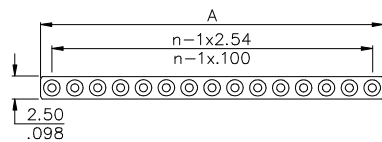
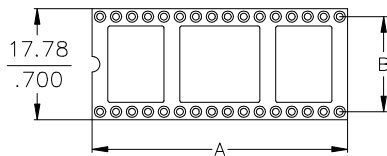
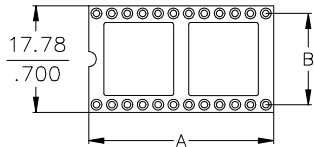
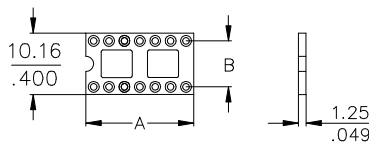

Pin	Dimensions mm/inch		Ordering Code
	"A"	"B"	
14	17,78/.700	7,62 .300	<b>LOP - 314 - S083 - 95</b>
16	20,32/.800		<b>LOP - 316 - S083 - 95</b>
18	22,86/.900		<b>LOP - 318 - S083 - 95</b>
20	25,40/1.000		<b>LOP - 320 - S083 - 95</b>
24	30,48/1.200		<b>LOP - 324 - S083 - 95</b>
24	30,48/1.200	15,24 .600	<b>LOP - 624 - S083 - 95</b>
28	35,56/1.400		<b>LOP - 628 - S083 - 95</b>
32	40,64/1.600	15,24 .600	<b>LOP - 632 - S083 - 95</b>
40	50,80/2.000		<b>LOP - 640 - S083 - 95</b>
10	25,40/1.000	15,24 .600	<b>SLP - 110 - S083 - 95</b>
14	35,56/1.400		<b>SLP - 114 - S083 - 95</b>

**Other sizes and flush head version on request**

**Pin-outs**

*Other pin-outs available on request.*

Despite the very low profile of these sockets the IC legs can be inserted completely.

**Recommended PCB Layout**

*Recommended drilling hole dia Ø 0,8mm/.031"*

**Low Profile Terminal**

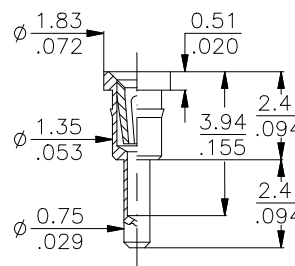

**083** 2.41mm / .095" over PCB

**Plating**

**Standard:**

- **95** = tin/gold  
*(tin leadfree)*

**Alternative**

- **55** = gold/gold  
- **99** = tin/ tin  
*(leadfree)*

**Specifications**

**Mechanical data**

Insertion force	1,80 N (avg)
Extraction force	0,90 N (avg)
Contact life	> 100 cycles
Solderability	as per IEC 60068-2-58
Contact security:	
-Vibration	as per EN60352-4
-Shock	as per EN60352-4

**Material**

Insulator <i>(RoHS compliant)</i>	PBT UL 94 V-0
Terminal <i>(RoHS compliant)</i>	CuZn
Contact <i>(RoHS compliant)</i>	BeCu

**Electrical data**

Contact resistance at 1A	4,3 mΩ typ.
Current rating	1A max., 100V
Contact capacitance at 1MHz	2 pF max.
Insulation resistance at 500V DC	5 × 10 <sup>9</sup> Ω min.
Breakdown voltage at 60 Hz	500 V AC
Contact resistance	≤ 7 mΩ

**Operating temperature**

-55° C to +125° C

**Pitch**

2,54 mm (.100")

**More information, for example about testresult please ref. to page 49 or contact E-tec.**

E-tec's super low profile sockets and adapters are designed for use in applications where height above board is most critical.

The sockets have a profile of 0,60mm above board and they can be combined with the adapters to achieve a board to board interconnection height of 2,20mm max.

Also available in this socket range are the ultra low profile SMT sockets with a height above board of only 3,45mm.

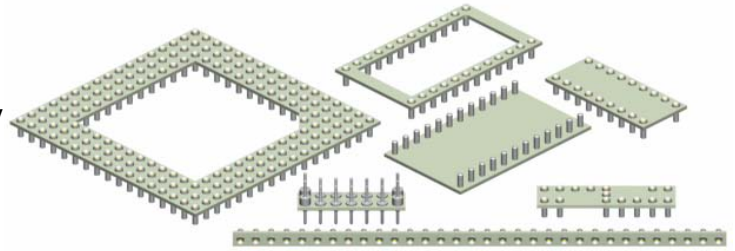

Super Low Profile Sockets						Super Low Profile Adapters	
SMT use			through hole use				
<b>Terminal style</b>	DIM "A"	DIM "B"	DIM "C"	DIM "D"	DIM "E"	<b>Adapter Pin</b>  <b>Style 377</b>	
<b>144</b>	3,45/.136	3,05/.120	0,94/.037	0,45/.018	1,15/.045		

## Specifications

### Mechanical data

Force per contact (avg) 0,70N insertion / 0.25N extraction  
 Contact life >50 cycles min.  
 Solderability as per IEC 60068-2-58

### Material

Terminal (RoHS compliant) BeCu  
 Insulator (RoHS compliant) Glass Epoxy FR4

### Electrical data

Breakdown voltage at 60 Hz 500 V AC  
 Contact resistance at 1A 4,3 mΩ typ  
 Insulation resistance 5 × 10<sup>9</sup> Ω min.  
 Current rating 1A max., 100V  
 Capacitance 2 pF max.

### Operating temperature

-55 °C to +125 °C

## How to order

XXX - x x x - E x x x ( - x x X ) - x x ( / x )

Series	DIP spacing	Nbr of contacts	Terminal styles	Plating	Pitch
<b>LSP</b> = DIP sockets <b>SSP</b> = SIP sockets <b>DSP</b> = 2-row SIP's <b>PGS</b> = PGA sockets <b>ZZS</b> = Zig-Zag sockets	see pages for LSP series for SSP series for DSP series for ZZS series for PGS series only nbr of contacts	POS SIB/SIS DIS ZZP PGA	See drawings above for 2,54mm and 2,00mm pitch. For 1,27mm pitch please contact nearest sales office.	- <b>95</b> = tin/gold (tin leadfree) (not available for adapter terminals) - <b>55</b> = gold/gold - <b>99</b> = tin/tin (leadfree)	Complete with <b>1</b> = 1,27mm <b>2</b> = 2,00mm 2.54mm pitch is standard. Others available on request

## Grid size & Configuration code only for PGA sockets

Please refer to PGA socket pages 29 to 31

# IC Sockets for Automatic Insertion

The terminals can be bent before and cut after the soldering process.

Open frame sockets with rails under the plastic as required by certain auto-insert machines.

Delivered in tubes with correct orientation.

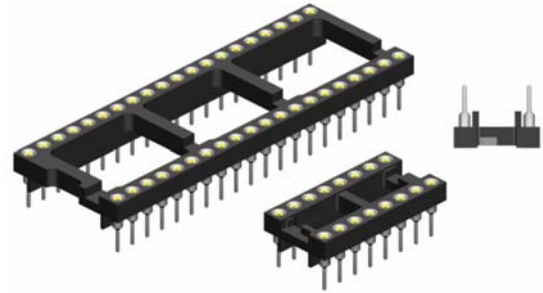

Socket Drawing "top view"		PIN	Dimensions mm/inch			Ordering Code		
DIM "B" = 7,62mm / .300"	DIM "B" = 15,24mm / .600"		"A"	"B"	"C"			
		08	10,16 / .400	7,62 .300	4,50 .177	<b>POA-308-Sxxx-95</b>		
		14	17,78 / .700			<b>POA-314-Sxxx-95</b>		
		16	20,32 / .800			<b>POA-316-Sxxx-95</b>		
		18	22,86 / .900			<b>POA-318-Sxxx-95</b>		
		20	25,40 / 1.000			<b>POA-320-Sxxx-95</b>		
		24	30,48 / 1.200			<b>POA-324-Sxxx-95</b>		
		28	35,56 / 1.400			<b>POA-328-Sxxx-95</b>		
		24	30,48 / 1.200	15,24 .600	12,00 .472	<b>POA-624-Sxxx-95</b>		
		28	35,56 / 1.400			<b>POA-628-Sxxx-95</b>		
		40	50,80 / 2.000			<b>POA-640-Sxxx-95</b>		
		Socket Drawing "side view"		Terminal styles				

Specifications			
<b>Mechanical data</b>		<b>Electrical data</b>	
Insertion force	1,80 N (avg)	Contact resistance at 1A	4,3 mΩ typ.
Extraction force	0,90 N (avg)	Current rating	1A max., 100V
Contact life	> 100 cycles	Contact capacitance at 1MHz	2 pF max.
Solderability	as per IEC 60068-2-58	Insulation resistance at 500V DC	5 × 10 <sup>9</sup> Ω min.
Contact security:		Breakdown voltage at 60 Hz	500 V AC
-Vibration	as per EN60352-4	Contact resistance	≤ 7 mΩ
-Shock	as per EN60352-4	<b>Operating temperature</b>	-55° C to +125° C
<b>Material</b>		<b>Pitch</b>	2,54 mm (.100")
Insulator (RoHS compliant)	PBT UL 94 V-0	<b>More information, for example about testresult please ref. to page 49 or contact E-tec.</b>	
Terminal (RoHS compliant)	CuZn		
Contact (RoHS compliant)	BeCu		

### How to order

**POA** - x x x - S x x x - x x

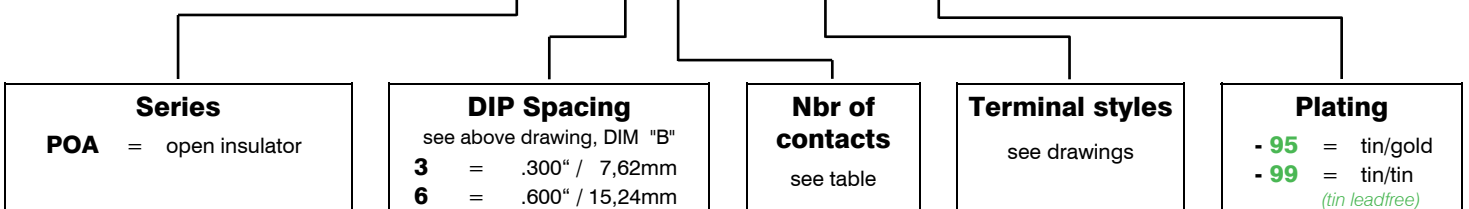

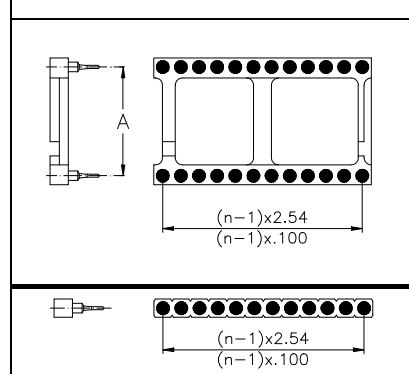
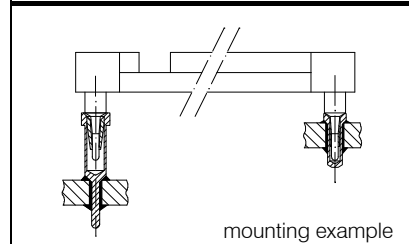
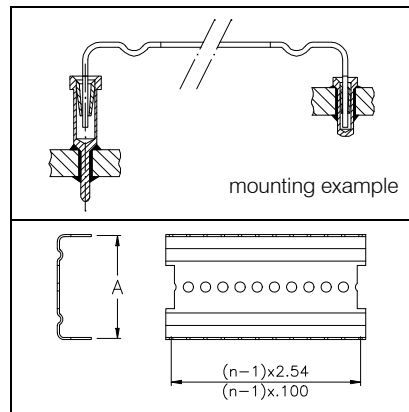
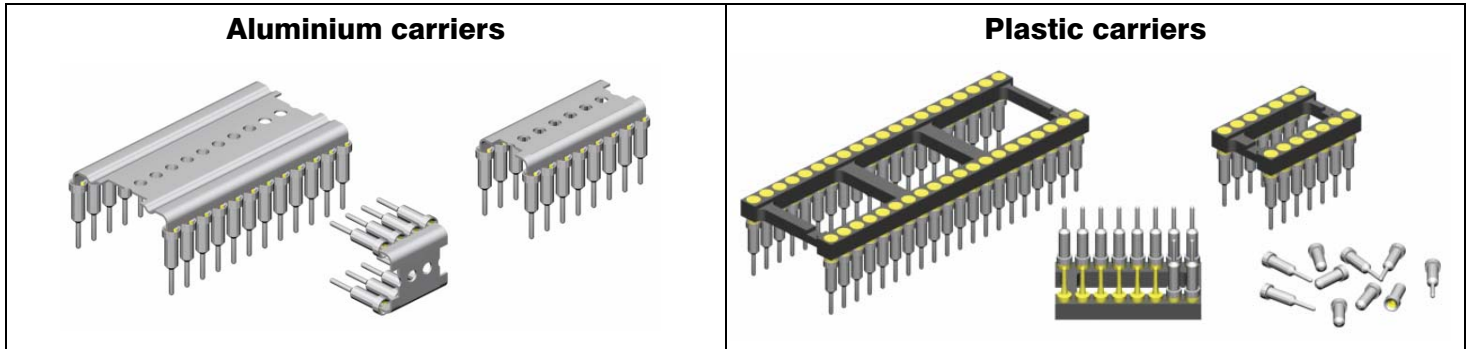

PIN	DIM "A" mm/inch	Ordering Code	
6	7,62/.300	<b>DCA-306-Sxxx-95</b>	
8		<b>DCA-308-Sxxx-95</b>	
14		<b>DCA-314-Sxxx-95</b>	
16		<b>DCA-316-Sxxx-95</b>	
18		<b>DCA-318-Sxxx-95</b>	
20		<b>DCA-320-Sxxx-95</b>	
22	15,24/.600	<b>DCA-322-Sxxx-95</b>	
24		<b>DCA-624-Sxxx-95</b>	
28		<b>DCA-628-Sxxx-95</b>	
40		<b>DCA-640-Sxxx-95</b>	
6		7,62/.300	<b>DCP-306-Sxxx-95</b>
8			<b>DCP-308-Sxxx-95</b>
10	<b>DCP-310-Sxxx-95</b>		
14	<b>DCP-314-Sxxx-95</b>		
16	<b>DCP-316-Sxxx-95</b>		
18	<b>DCP-318-Sxxx-95</b>		
20	15,24/.600	<b>DCP-320-Sxxx-95</b>	
24		<b>DCP-324-Sxxx-95</b>	
28		<b>DCP-328-Sxxx-95</b>	
24		<b>DCP-624-Sxxx-95</b>	
28		<b>DCP-628-Sxxx-95</b>	
32		<b>DCP-632-Sxxx-95</b>	
36	<b>DCP-636-Sxxx-95</b>		
40	<b>DCP-640-Sxxx-95</b>		
48	<b>DCP-648-Sxxx-95</b>		
2 to 32	single strip	<b>SCP-1xx-Sxxx-95</b>	
4 to 80	double strip	<b>SCP-2xx-Sxxx-95</b>	

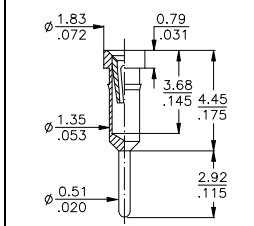
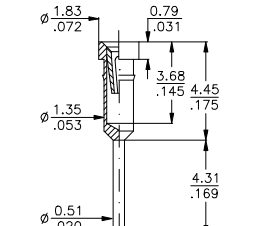
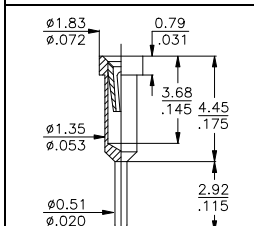
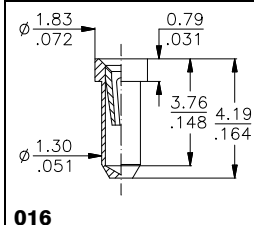
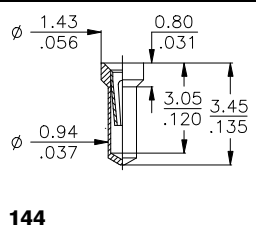
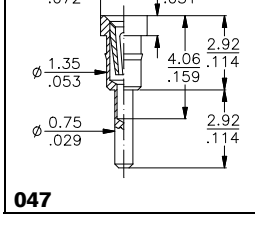
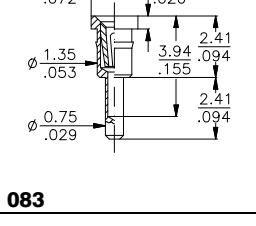
	
<b>001</b>	<b>008</b>
	
<b>012</b>	
	
<b>016</b>	<b>144</b>
	
<b>047</b>	<b>083</b>

**Specifications**  
See page 49 of this catalogue

**Terminals**  
For other terminal styles please refer to the pages 46 to 48 of this catalogue or contact your closest sales office.

**Carrier Material**  
DCP & SCP series : PBT or high temp plastic UL 94 V-0 depending on pincount  
DCA series : Aluminum

How to order

**XXX - x xx - S xxx - 95**

Series	
<b>DCA</b>	= DIL Alu Carrier
<b>DCP</b>	= DIL Plastic Carrier
<b>SCP</b>	= SIL Plastic Carrier

Pitch	
<b>1</b>	= only for SCP Series
<b>2</b>	= only for SCP Series
<b>3</b>	= .300" / 7,62mm
<b>4</b>	= .400" / 10,16mm
<b>6</b>	= .600" / 15,24mm
<b>9</b>	= .900" / 22,86mm

Nbr of contacts	
see Ordering Code table above	

Terminal style	
see drawings above	
or refer to pages 46 to 48 of this catalogue for other types.	

Plating	
<b>- 95</b>	= tin/gold (tin leadfree)

**SMT IC Sockets**

2,54mm pitch

**Straight Terminal SMT Sockets - 093 Style -**

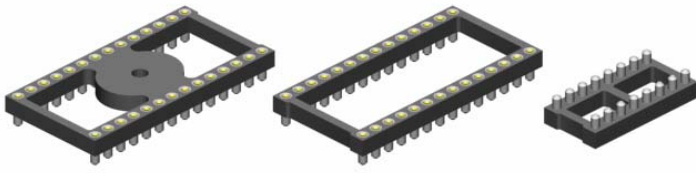

**Gullwing Terminal SMT Sockets - 094 & R94 Style -**

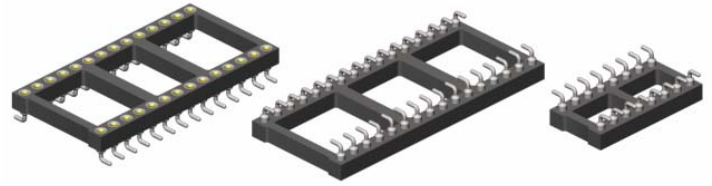

**093 Style Straight**

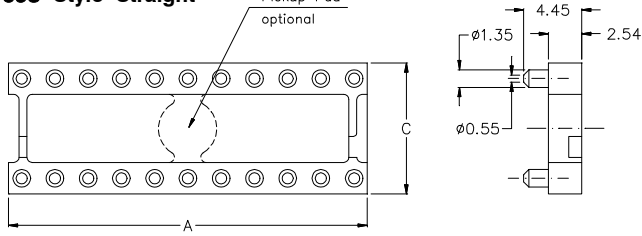

**PCB layout**

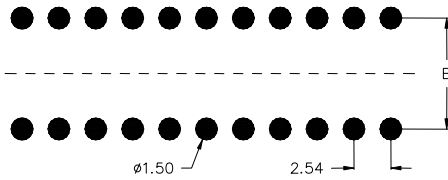

**Dimensions (mm/inch)**

Pin	Dimensions (mm/inch)			Ordering Code
	"A"	"B"	"C"	
6	7,62/.300	7,62 .300	10,16 .400	<b>PSO-306-H093-95</b>
8	10,16/.400			<b>PSO-308-H093-95</b>
10	12,70/.500			<b>PSO-310-H093-95</b>
14	17,78/.700			<b>PSO-314-H093-95</b>
16	20,32/.800			<b>PSO-316-H093-95</b>
18	22,86/.900			<b>PSO-318-H093-95</b>
20	25,40/1.000	15,24 .600	17,78 .700	<b>PSO-320-H093-95</b>
24	30,48/1.200			<b>PSO-624-H093-95</b>
28	35,56/1.400			<b>PSO-628-H093-95</b>
32	40,64/1.600			<b>PSO-632-H093-95</b>
36	45,72/1.800			<b>PSO-636-H093-95</b>
40	50,80/2.000			<b>PSO-640-H093-95</b>
48	60,96/2.400			<b>PSO-648-H093-95</b>

**094 Style Gullwing**

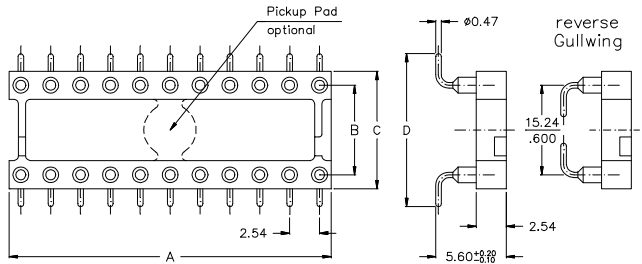

**R94 Style**

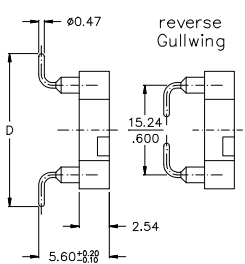

**PCB layout**

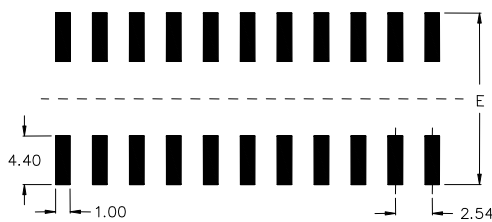

**Dimensions (mm/inch)**

Pin	Dimensions (mm/inch)					Ordering Code
	"A"	"B"	"C"	"D"	"E" 094 Style	
10	12,70/.500	5,08 .200	7,62 .300	10,46 .412	15,00 .590	<b>PSO-210-H094-95</b>
6	7,62/.300	7,62 .300	10,16 .400	13,00 .512		<b>PSO-306-H094-95</b>
8	10,16/.400					<b>PSO-308-H094-95</b>
10	12,70/.500					<b>PSO-310-H094-95</b>
14	17,78/.700					<b>PSO-314-H094-95</b>
16	20,32/.800					<b>PSO-316-H094-95</b>
18	22,86/.900				<b>PSO-318-H094-95</b>	
20	25,40/1.000	15,24 .600	17,78 .700	20,70 .815	22,70 .894	<b>PSO-320-H094-95</b>
24	30,48/1.200					<b>PSO-624-Hxxx-95</b>
28	35,56/1.400					<b>PSO-628-Hxxx-95</b>
32	40,64/1.600					<b>PSO-632-Hxxx-95</b>
36	45,72/1.800					<b>PSO-636-Hxxx-95</b>
40	50,80/2.000					<b>PSO-640-Hxxx-95</b>

**Body types**

Standard = Open frame (PSO Series)  
Optional = Closed frame (PSC Series)

**Insulator**

high-temp plastic UL 94 V-0 (RoHS compliant)  
For further technical data refer to page 49

**Temperature**

Operating temp. -55 °C to +125 °C  
Processing temp. +250°C +/-5°C for 20~40sec.

**How to order**

**PSO - x x x - H x x x - 95 ( / P )**

if with Pickup Pad  
only 28- & 32-pin  
-others on request-

**Series**

**PSO** = open frame  
**PSC** = closed frame  
please contact sales office  
for more details

**DIP spacing**

in inch  
see table, Dim "B"  
Example:  
**3** for ".300"

**Nbr of contacts**

see table  
Example:  
**06** for 6 Pin

**Terminal styles**

**093** = straight  
**094** = gullwing  
**R94** = reverse gullwing  
**933** = floating on request

**Plating**

**- 95** = tin/gold  
(tin leadfree)  
others on request

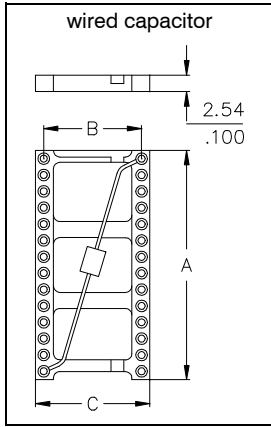
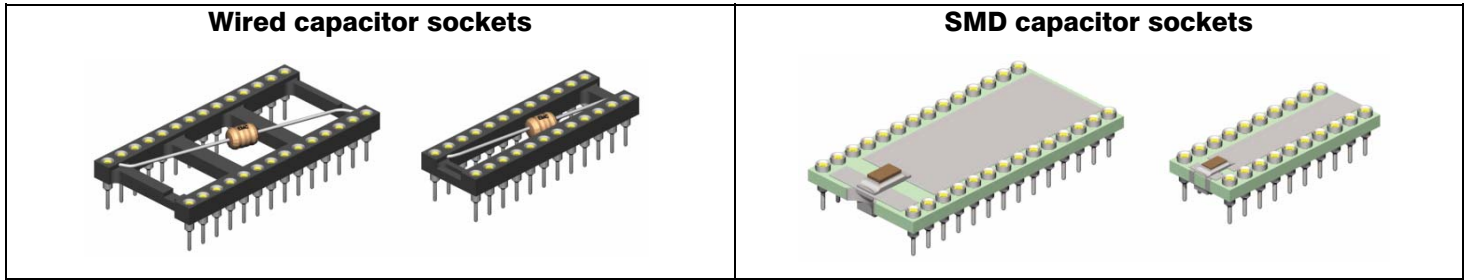

Pin	"A"	"B"	"C"	Ordering code
8	10,16/.400	7.62 .300	10.16 .400	<b>QIT-308-W001-95</b>
14	17,78/.700			<b>QIT-314-W001-95</b>
16	20,32/.800			<b>QIT-316-W001-95</b>
18	22,86/.900			<b>QIT-318-W001-95</b>
20	25,40/1.00			<b>QIT-320-W001-95</b>
24	30,48/1.20			<b>QIT-324-W001-95</b>
28	35,56/1.40	15.24 .600	17.78 .700	<b>Not available</b>
24	30,48/1.20			<b>QIT-624-W001-95</b>
28	35,56/1.40			<b>QIT-628-W001-95</b>
32	40,64/1.60			<b>QIT-632-W001-95</b>
40	50,80/2.00			<b>QIT-640-W001-95</b>

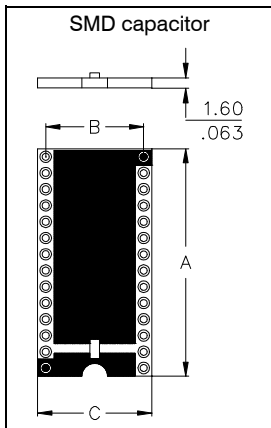
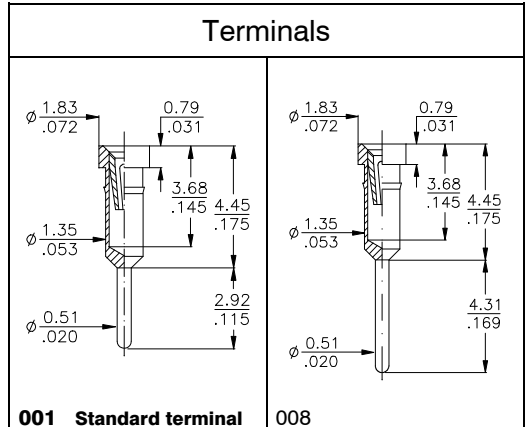

Pin	"A"	"B"	"C"	Ordering code
8	10,16/.400	7.62 .300	10.16 .400	<b>QIT-308-S001-95</b>
14	17,78/.700			<b>QIT-314-S001-95</b>
16	20,32/.800			<b>QIT-316-S001-95</b>
18	22,86/.900			<b>QIT-318-S001-95</b>
20	25,40/1.00			<b>QIT-320-S001-95</b>
24	30,48/1.20			<b>QIT-324-S001-95</b>
28	35,56/1.40	15.24 .600	17.78 .700	<b>QIT-328-S001-95</b>
24	30,48/1.20			<b>QIT-624-S001-95</b>
28	35,56/1.40			<b>QIT-628-S001-95</b>
32	40,64/1.60			<b>QIT-632-S001-95</b>
40	50,80/2.00			<b>QIT-640-S001-95</b>

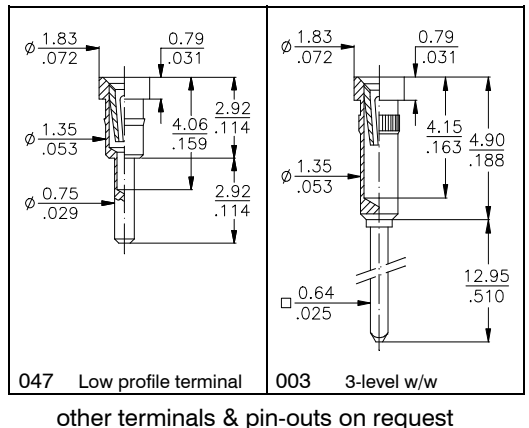

other terminals & pin-outs on request

**Socket Specifications**

<b>Mechanical data</b>	Insertion force: 1,80 N (avg) Extraction force: 0,90 N (avg) Contact life: > 100 cycles Solderability: as per IEC 60068-2-58 Contact security: -Vibration: as per EN60352-4 -Shock: as per EN60352-4
<b>Material</b>	Insulator: (RoHS compliant) Hi temp plastic UL 94 V-0 (wired version) Epoxy FR4 if with SMD capacitor Terminal: (RoHS compliant) CuZn Contact: (RoHS compliant) BeCu

<b>Electrical data</b>	Contact resistance at 1A: 4,3 mΩ typ. Current rating: 1A max., 100V Contact capacitance at 1MHz: 2 pF max. Insulation resistance at 500V DC: 5 × 10 <sup>9</sup> Ω min. Breakdown voltage at 60 Hz: 500 V AC Contact resistance: ≤ 7 mΩ
<b>Operating temperature</b>	-55° C to +125° C
<b>Pitch</b>	2,54 mm (.100")

**More information, for example about testresult please ref. to page 49 or contact E-tec.**

**Capacitor Specifications**

<b>General data</b>	Ceramic material: Z5U Voltage: 50 V	<b>Available capacitor values</b>	Standard type: 100nF (0.1 μF) Alternatives: 10nF (0.01 μF)
---------------------	--	-----------------------------------	---

**How to order**

QIT - x x x - X x x x - 95 (/ x)

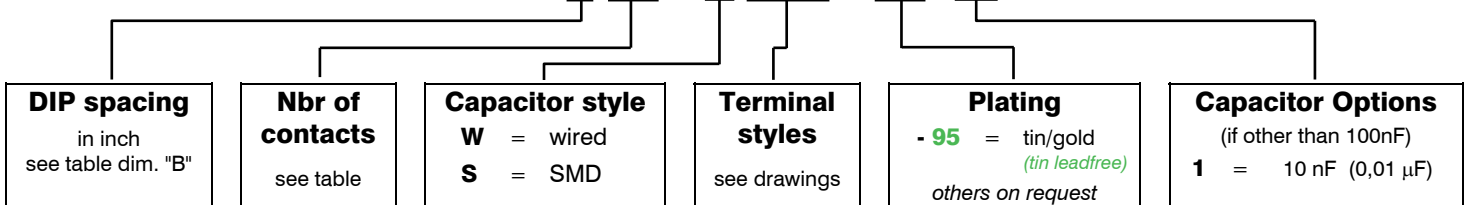

Available in sizes of 6 to 48 pins.

Low profile & dual-beam contact design.

Contact design incorporates anti-overstress feature.

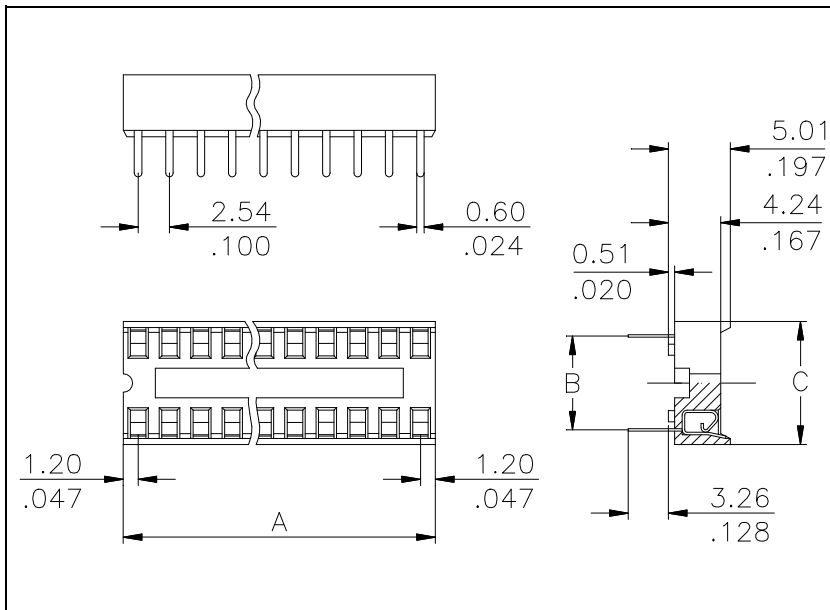
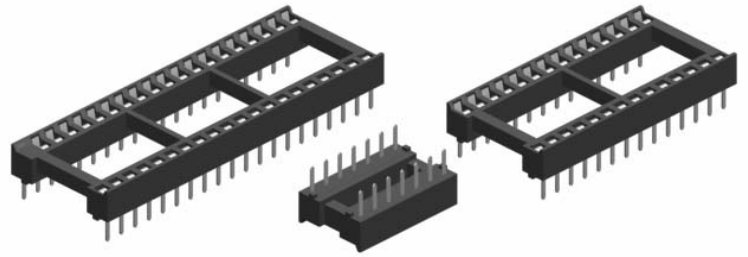

Pin	Dimensions mm/inch			Ordering Code
	"A"	"B"	"C"	
6	7,49/.295	7,62 / .300	10,16 / .400	<b>LOC-306-T051-99</b>
8	10,03/.795			<b>LOC-308-T051-99</b>
14	17,65/.695			<b>LOC-314-T051-99</b>
16	20,19/.795			<b>LOC-316-T051-99</b>
18	22,73/.895			<b>LOC-318-T051-99</b>
20	25,27/.995			<b>LOC-320-T051-99</b>
24	30,35/1.195			<b>LOC-324-T051-99</b>
28	35,43/1.395			<b>LOC-328-T051-99</b>
22	27,81/1.095	10,16 / .400	12,70 / .500	<b>LOC-422-T051-99</b>
24	30,35/1.195	15,24 / .600	17,70 / .700	<b>LOC-624-T051-99</b>
28	35,43/1.395			<b>LOC-628-T051-99</b>
32	40,51/1.595			<b>LOC-632-T051-99</b>
40	50,67/1.995			<b>LOC-640-T051-99</b>
42	53,21/2.095			<b>LOC-642-T051-99</b>
48	60,83/2.395			<b>LOC-648-T051-99</b>

Low Cost DIP are also available with the "Shrink" pitch 1,778mm / .070". Please request separate datasheets.

**Specification**

**Mechanical data**

Insertion force 2 N max.  
 Extraction force 0,5 N min.  
 Contact reliability 50 cycles min

**Material**

Insulator (RoHS compliant) std. temp PBT plastic UL 94 V-0  
 Contact (RoHS compliant) Phosphor bronze

**Electrical data**

Contact resistance 10 mΩ typ.  
 Current rating 1A max., 100V  
 Contact capacitance 0,5 pF  
 Insulation resistance 1000 MΩ min.  
 Breakdown voltage 1 KV min.

**Operating temperature**

-50°C to +125°C

How to order

LOC - x xx - T051 - 99

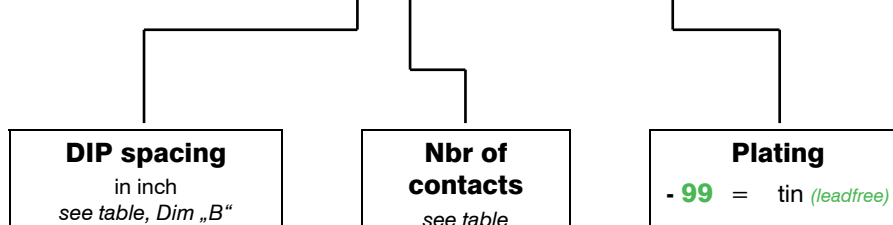

Precision Shrink Sockets 1,778mm/.070" pitch

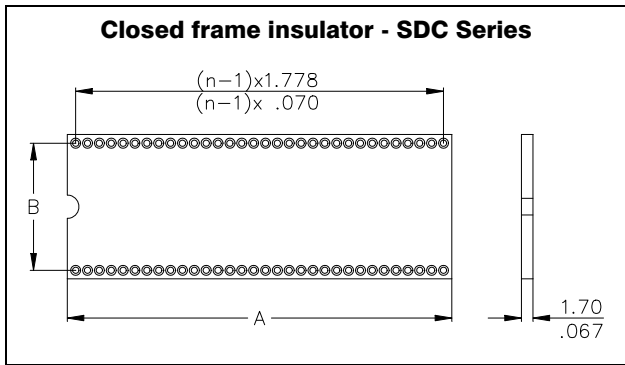
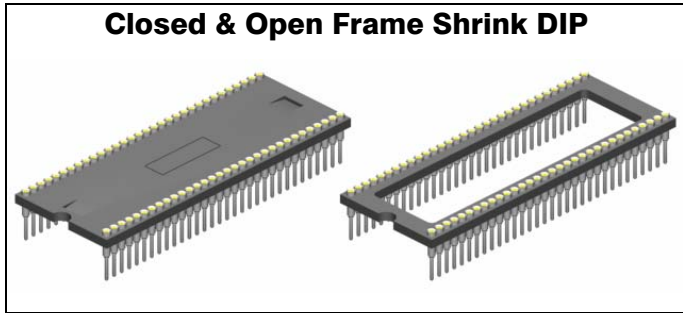

Pin	Dimensions mm/inch		Ordering Code
	"A"	"B"	
24	22,09 / .870	10,16 .400	<b>SDC-424-Exxx-xx</b>
28	25,65 / 1.010		<b>SDC-628-Exxx-xx</b>
40	36,32 / 1.430	15,24 .600	<b>SDC-640-Exxx-xx</b>
42	36,32 / 1.430		<b>SDC-642-Exxx-xx</b>
64	57,65 / 2.270	19,05 .750	<b>SDC-764-Sxxx-xx</b>

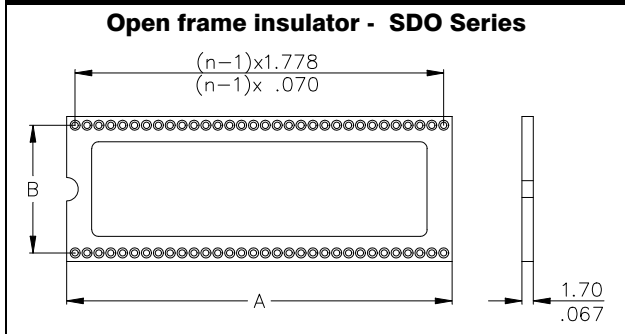
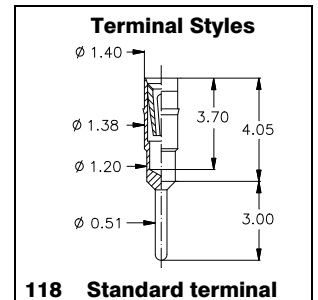

64	57,65 / 2.270	19,05 .750	<b>SDO-764-Sxxx-xx</b>
----	---------------	---------------	------------------------

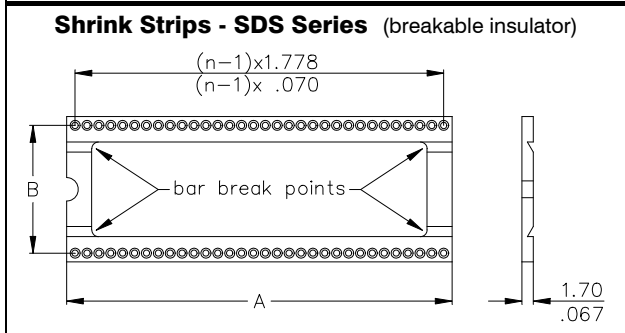
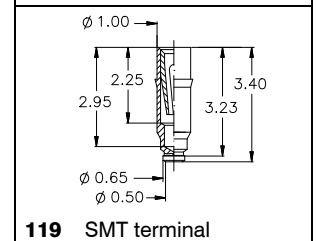

2 x 32	57,65 2.270	19,05 .750	<b>SDS-232-Sxxx-xx</b>
--------	----------------	---------------	------------------------

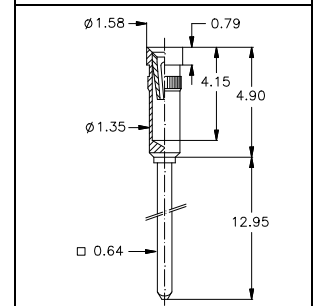

**Technical Data :**  
 Insertion force 0.70 N (avg.)  
 Extraction force 0.25 N (avg.)

For further data refer to page 49 in this catalogue.

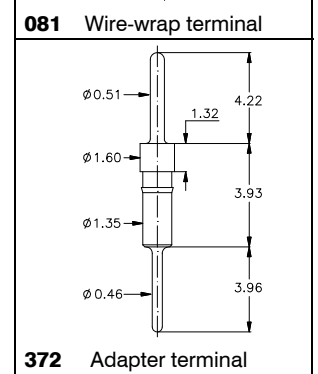

How to order

XXX - xxx - Xxxx - xx

**Series**  
**SDC** = closed frame  
**SDO** = open frame  
**SDS** = strips

**DIP spacing**  
 Dim "B" in inch  
 Example:  
**6** for ".600"

**Nbr of contacts**  
 see table

**Insulator**  
**S** = Plastic  
**E** = FR 4 (Epoxy)

**Terminal styles**  
 see drawings  
*others on request*

**Plating**  
**- 95** = tin/gold (not for terminal 372)  
**- 55** = gold/gold  
**- 99** = tin/tin (tin is leadfree)

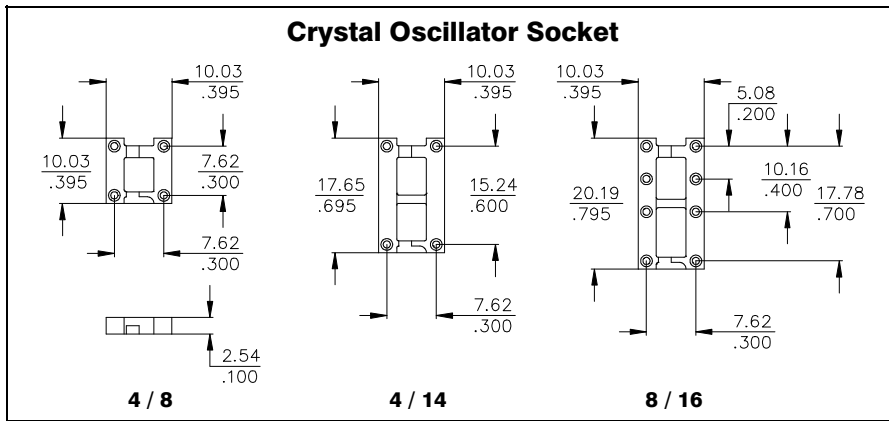
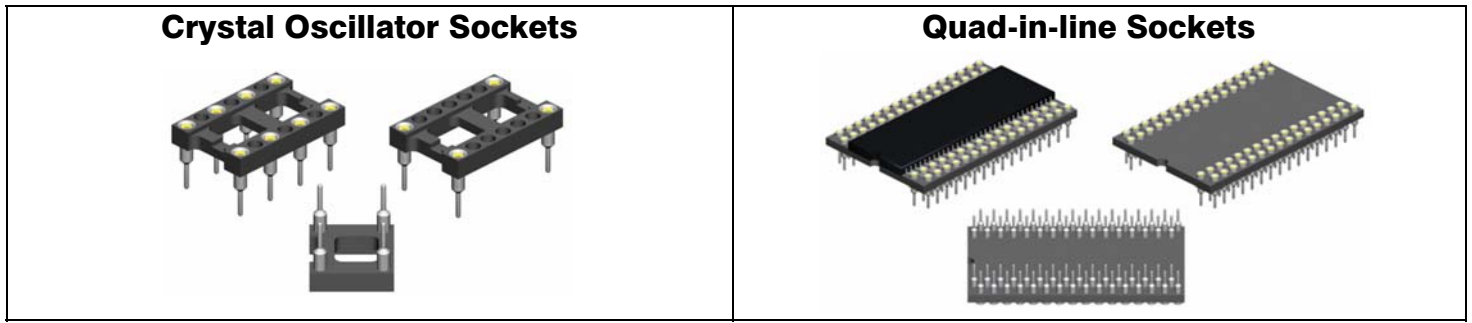

### Crystal Oscillator Sockets

Pin	Ordering Code
4 / 8	<b>COS-084-S001-95</b>
4 / 14	<b>COS-144-S001-95</b>
8 / 16	<b>COS-168-S001-95</b>

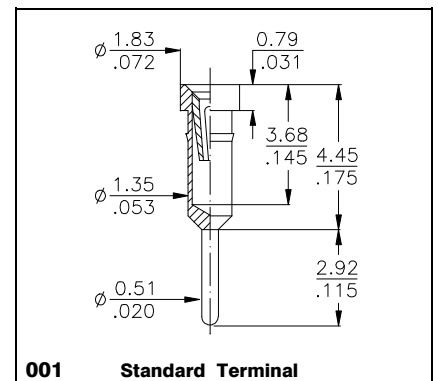
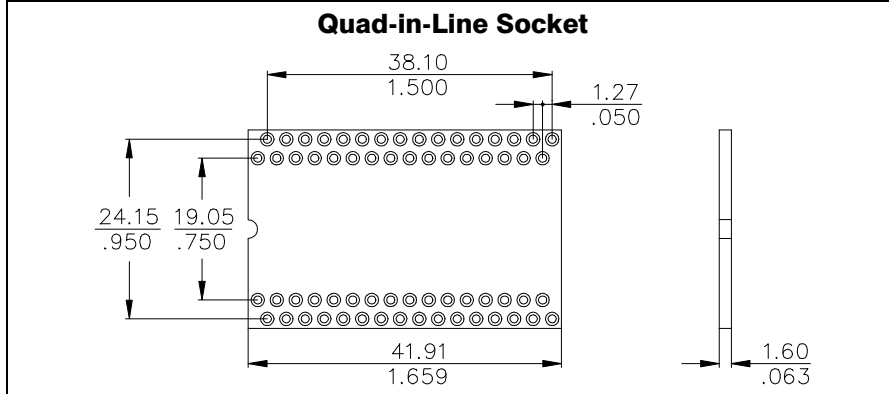

### Quad-in-line Socket

Pin	Ordering Code
64	<b>QIL-764-S001-95</b>

for Rockwell & NEC Chip

Other pin-outs available on request.

Specifications			
<b>Mechanical data</b>	Insertion force	1,80 N for COS & 0.70N for QIL	4,3 mΩ typ. 1A max., 100V
	Extraction force	0,90 N for COS & 0.25N for QIL	
<b>Material</b>	Contact life	> 100 cycles	2 pF max.
	Solderability	as per IEC 60068-2-58	Insulation resistance at 500V DC
<b>Electrical data</b>	Contact security:	as per EN60352-4	Breakdown voltage at 60 Hz
	-Vibration	as per EN60352-4	Contact resistance
<b>Operating temperature</b>	-Shock	as per EN60352-4	500 V AC
			≤7 mΩ
			Pitch
			-55° C to +125° C
			2,54 mm (.100")

**Material**  
 Insulator (RoHS compliant) COS Series: hi temp plastic UL 94 V-0  
 QIL Series: PBT plastic UL 94 V-0  
 Terminal (RoHS compliant) CuZn  
 Contact (RoHS compliant) BeCu

**More information, for example about testresult please ref. to page 49 or contact E-tec.**

### How to order

XXX - xxx - S001 - 95

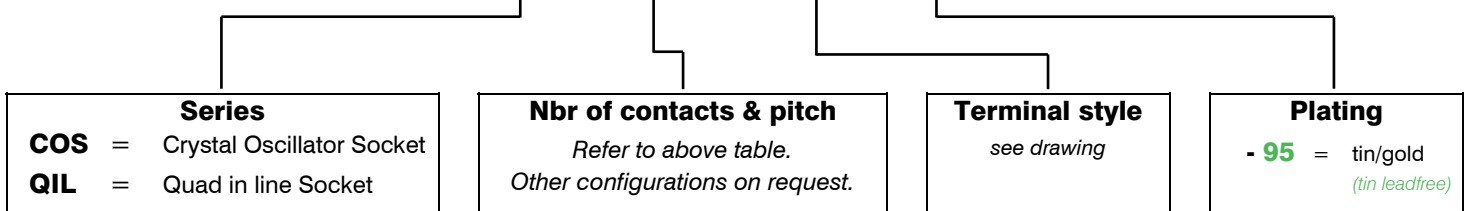

LED Sockets

2,54mm pitch

LED socket mounted with precision turned pins ensure perfect contact reliability.

The sockets are available in horizontal and vertical executions.

The contacts are designed to hold many different IC's and LED's with short leads.

The LED sockets are also designed to accept DIP Switches.

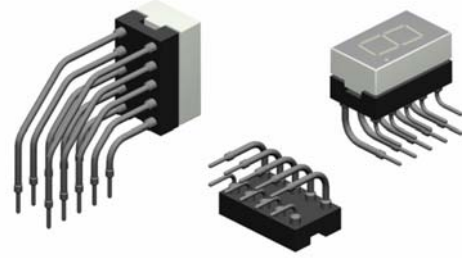

LEH Series - Horizontal -

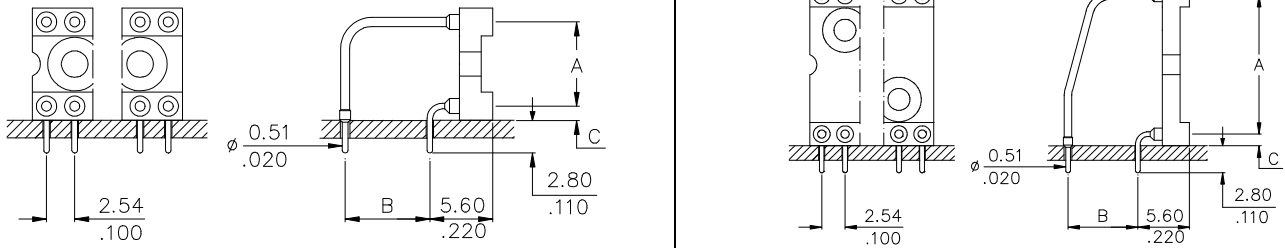

Ordering Code	Dimensions of the various socket types					
	Standard type -900-		Option -901	Option -902	Option -903	all types
pin-outs on request	Dim. "A"	Dim. "B"	Dim. "B"		Dim. "C"	
LEH - 2 xx - S xxx - 95	5,08/.200	5,08/.200	2,54/.100	7,62/.300	-	1,27/.050
LEH - 3 xx - S xxx - 95	7,62/.300	7,62/.300	2,54/.100	5,08/.200	-	1,27/.050
LEH - 4 xx - S xxx - 95	10,16/.400	10,16/.400	2,54/.100	5,08/.200	7,62/.300	1,27/.050
LEH - 6 xx - S xxx - 95	15,24/.600	7,62/.300	15,24/.600	-	-	1,27/.050
LEH - 6 xx - S904 - 95	15,24/.600	7,62/.300	-	-	-	2,87/.112

LEV Series - Vertical -

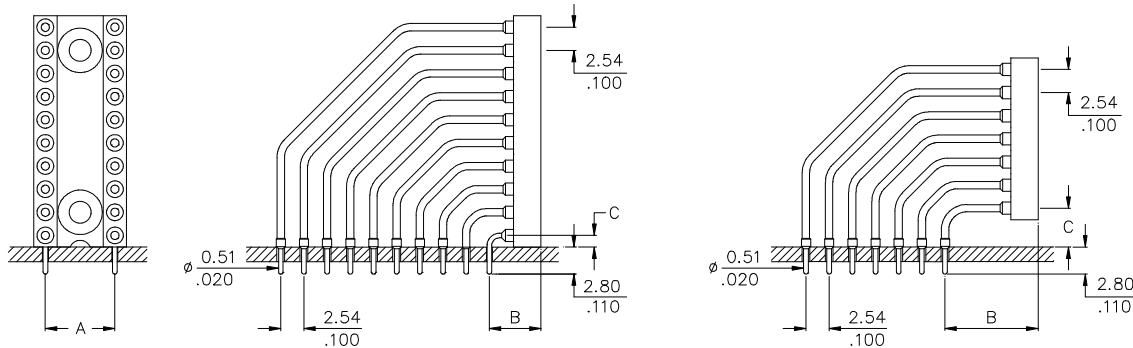

Drawing for standard socket type -910

Drawing for all other options

Ordering Code	Dimensions								
	all types	Standard Type -910		Options -915		Options -916		Options -917	
pin-outs on request	"A"	"B"	"C"	"B"	"C"	"B"	"C"	"B"	"C"
LEV - 2 xx - S xxx - 95	5,08/.200	5,60/.220	1,27/.050	8,14/.320	3,81/.150	10,68/.420	6,35/.250	13,22/.520	
LEV - 3 xx - S xxx - 95	7,62/.300	5,60/.220	1,27/.050	8,14/.320	3,81/.150	10,68/.420	6,35/.250	13,22/.520	
LEV - 6 xx - S xxx - 95	15,24/.600	5,60/.220	1,27/.050	8,14/.320	3,81/.150	10,68/.420	6,35/.250	13,22/.520	

LEV - 3 xx - S911 - 95	7,62/.300	10,16/.400	4,87/.192
------------------------	-----------	------------	-----------

For technical specifications please refer to page 49

How to order

LE X - x xx - S xxx - 95

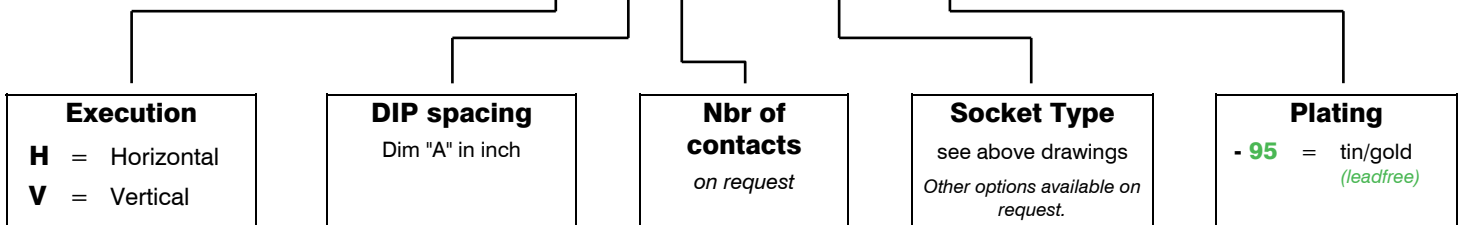

Sockets for TO-5 and TO-18 packages.  
 3-pole for transistors  
 and 2-pole TR-5 Fuse Holders shown on this page.  
 Embedded terminals prevent shortings.  
 High contact reliability with the 4-finger clips.

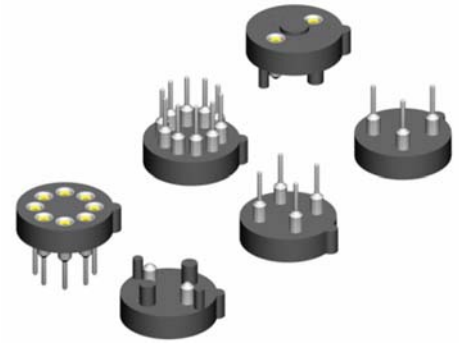

Transistor- & TO-Sockets				
3 - pin	4 - pin	8 - pin	10 - pin	
TOS-503-S118-95	TOS-504-S118-95	TOS-508-S118-95	TOS-610-S118-95	← Order Codes

Specifications	
<p><b>Mechanical data</b></p> <p>Insertion force 1,80 N (avg)                      Extraction force 0,90 N (avg)                      Contact life &gt; 100 cycles                      Solderability as per IEC 60068-2-58                      Contact security: as per EN60352-4                      -Vibration as per EN60352-4                      -Shock as per EN60352-4</p> <p><b>Material</b></p> <p>Insulator (RoHS compliant) PBT UL 94 V-0                      Terminal (RoHS compliant) CuZn                      Plating Sn (leadfree), Ni underplated                      Contact (RoHS compliant) BeCu                      Plating Au, Ni underplated</p>	<p><b>Electrical data</b></p> <p>Contact resistance at 1A 4,3 mΩ typ.                      Current rating 1A max., 100V                      Contact capacitance at 1MHz 2 pF max.                      Insulation resistance at 500V DC 5 × 10<sup>9</sup> Ω min.                      Breakdown voltage at 60 Hz 500 V AC                      Contact resistance ≤ 7 mΩ</p> <p><b>Operating temperature</b> -55° C to +125° C</p> <p><i>More information, for example about testresult please ref. to page 49 or contact E-tec.</i></p>

Socket for TR 5 Fuses	Specifications
	<p>( vary from the above )</p> <p><b>Electrical</b></p> <p>Contact resistance at 1A 4,3 mΩ typ.                      Current rating at 250 V; 1,6 W 6,3 A max.                      short time 45 sec. 9 A                      15 sec. 11 A                      5 sec. 16 A</p> <p><b>Mechanical</b></p> <p>Insertion force &gt; 13 N                      Extraction force &lt; 4 N</p> <p><b>Probe diam.</b> 0,58 - 0,62mm</p> <p><b>Material</b></p> <p>Insulator (RoHS compliant) Stanyl PA 46 Type UL 94 V-0</p> <p><b>Temperature</b></p> <p>Operating temperature -55° to +125°C                      Processing temperature +250°C +0/-5°C for 20-40sec.</p>
TOS-202-S001-95	